

# T20

Mini Booster Pump  
50/60 Hz

PRODUCT CATALOGUE



# MINI BOOSTER PUMP

## Permanent Magnet Motor

### Product Description

T20 is a household small automatic booster pump using DC brushless permanent magnet copper motors, centrifugal impellers, and a fully waterproof structure, safe and reliable, energy saving, and low noise.

### Applications:

- Electric, solar water heaters boosting.
- Shower booster (hot and cold water)
- Bathroom water boosting (faucet, closetool).
- Pressurized water supply for washing machines, etc.



### Performance Curve

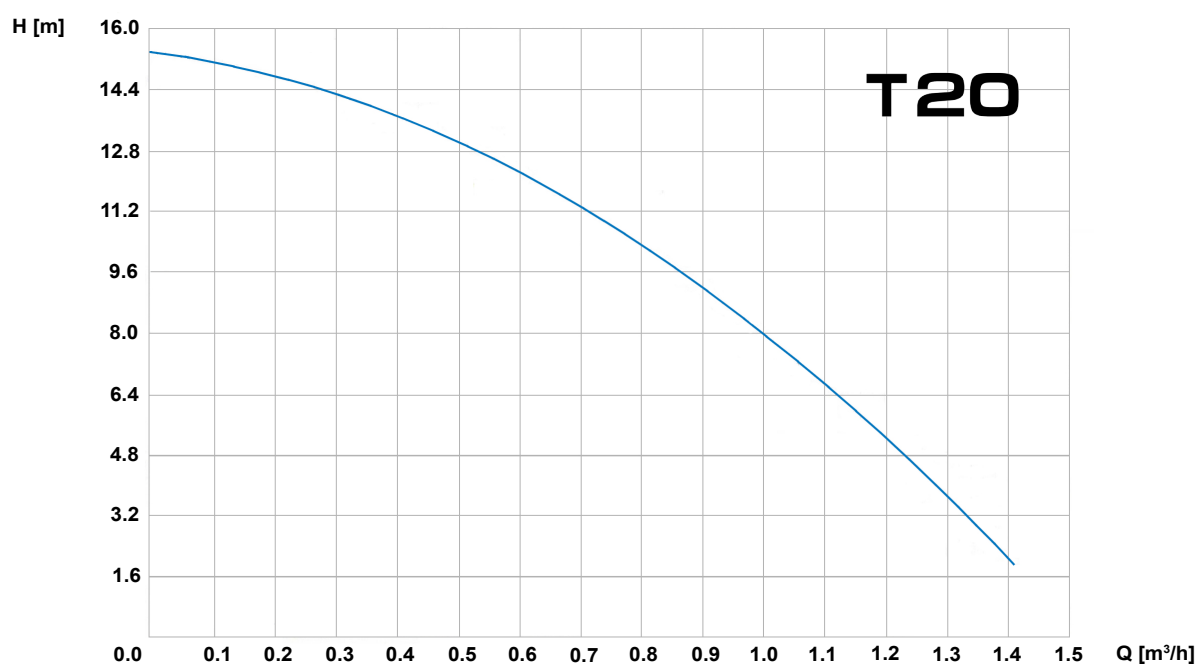

# FEATURES & ADVANTAGES

## Smart & Safe

### Model Description

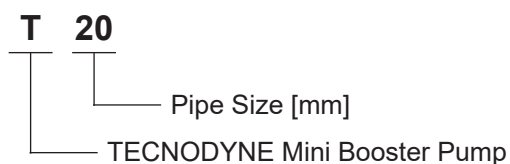

### Key Features:

- Fully automatic (starting flow 0.1 m³/h)
- Energy Saving.
- Reliable & silent pump.
- Water-cooled permanent magnet motor.
- Pump hot water up to 90°C
- Multiple Protection
- Optimized hydraulic design



### Material of construction:

Pump body: PPO+GF30

Impeller: PPO

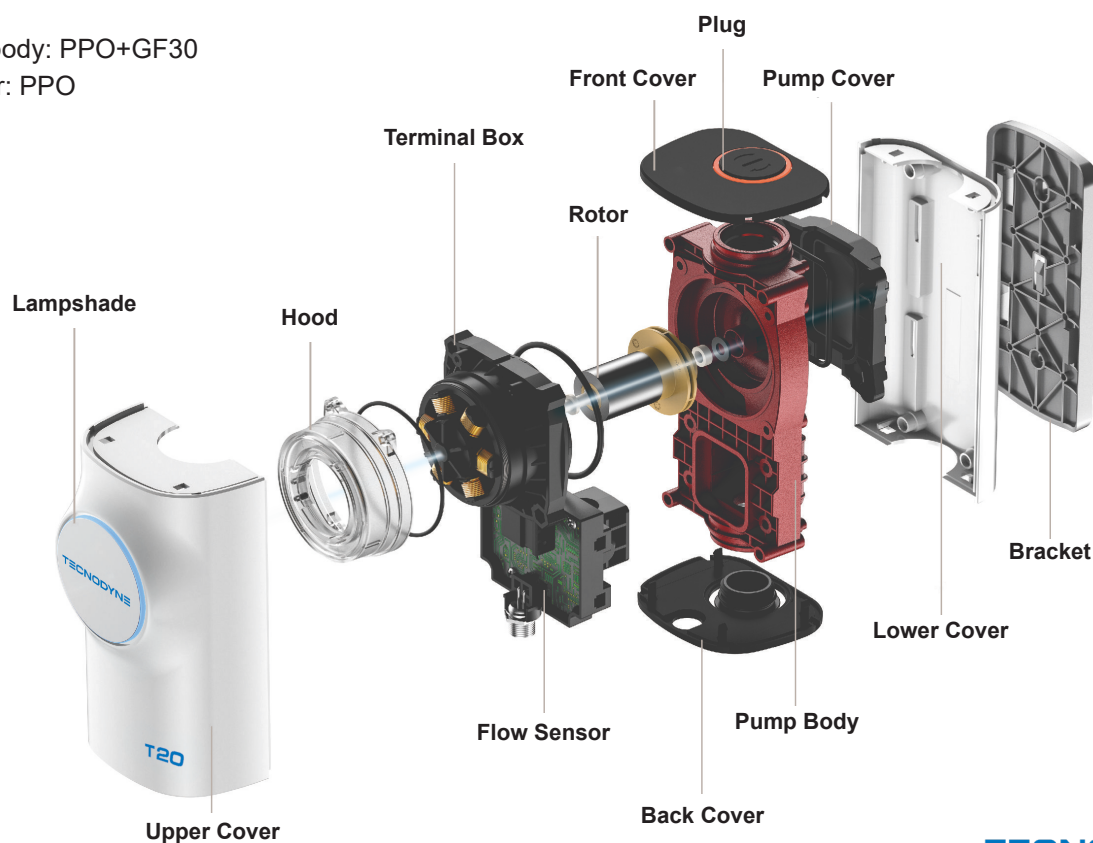

# PRODUCT OVERVIEW

Efficient & Reliable

## Technical Data

<b>Product Model</b>	<b>T 20</b>
<b>Voltage (input to controller)</b>	AC 100-240V, 1 ph
<b>Voltage (output)</b>	DC-24V
<b>Frequency</b>	50 / 60 Hz
<b>Power</b>	80 W
<b>Rated Current</b>	1 Amps
<b>Max Current</b>	3.4 Amps
<b>Max. Flow</b>	1.4 m <sup>3</sup> /h
<b>Rated Flow</b>	1 m <sup>3</sup> /h
<b>Starting Flow</b>	0.1 m <sup>3</sup> /h
<b>Max. Head</b>	15 m
<b>Rated Head</b>	9 m
<b>Max. System Pressure</b>	1.5 bar
<b>Min / Max. ambient temperature</b>	5 °C / 55 °C
<b>Min / Max water temperature</b>	5 °C / 90 °C
<b>Noise level</b>	≤ 55 db(A)
<b>Protection class</b>	IP55
<b>Inlet / Outlet Diameter</b>	20 mm
<b>Power cable length</b>	1.2 m
<b>Motor</b>	Permanent Magnet Motor (Copper winding)
<b>Max speed</b>	7000 rpm
<b>Motor cooling</b>	Water-cooled
<b>Insulation Class</b>	F

# DIMENSIONAL DRAWINGS

## Smart Compact Design

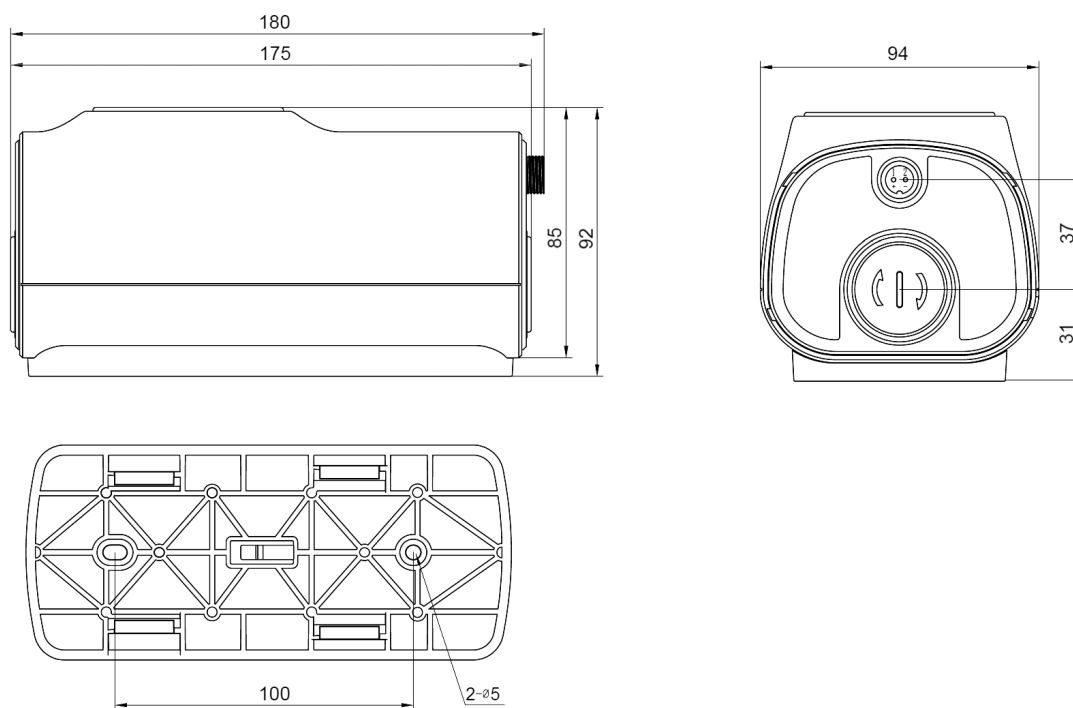

<b>Product Model</b>	<b>T 20</b>
<b>Product Number</b>	211010
<b>Product Dimensions</b>	175 x 94 x 85 mm
<b>Net Weight</b>	1.3 kg
<b>Packaging Dimensions</b>	240 x 225 x 105 mm
<b>Gross Weight</b>	2.1 kg
<b>Number of pieces per Carton</b>	6 pcs / ctn
<b>Gross Weight per Carton</b>	13 kg
<b>Number of Cartons per Pallet</b>	60 ctns / pallet (or 360 pcs / pallet)
<b>Warranty</b>	12 Months

TECNODYNE PUMPS INC. reserves the right to modify any specification without notice.

# TECNODYNE



## TECNODYNE PUMPS INC.

02 Sheppard Ave E, North York  
Ontario, Canada M2N 5Y7  
T: +1 438-308-2072  
[info@tecnodyne.ca](mailto:info@tecnodyne.ca)  
[www.tecnodyne.ca](http://www.tecnodyne.ca)