

TST Series

Close-Coupled End Suction Centrifugal Pumps 60Hz

PRODUCT CATALOGUE

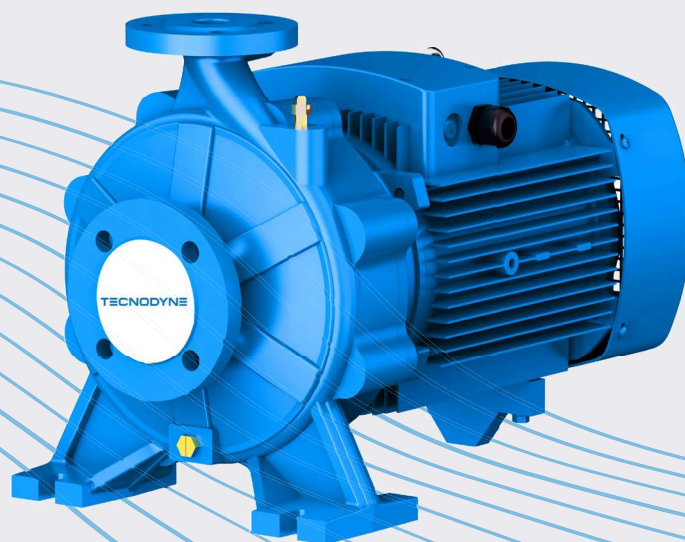

PRODUCT OVERVIEW

Energy Saving & Low-Noise

Product Description

TST is a close-coupled, single impeller centrifugal pump in compliance with EN733 standards. It is built to ensure durability and easy operation, making it a reliable choice for many applications. Featuring a high-efficiency motor with IP55 class F protection, a pump casing with anti-corrosive coating, quality NSK bearing, and a wear-resistant mechanical seal.

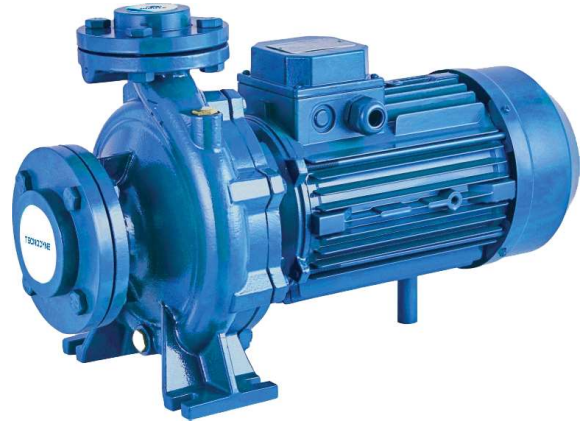

Model Description

TST m 32 - 250 / 75 D

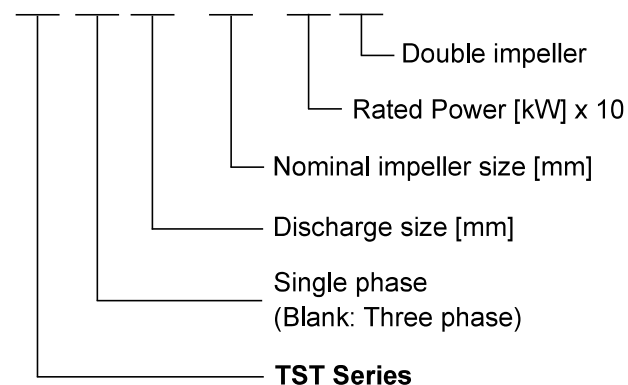

- Medium temperature: -10~120°C
- Max. ambient temperature: -10~50°C
- Max. working pressure: 16 bar

Material

Casing: Grey cast iron

Impeller: Cast iron/AISI 304/Brass

Shaft: 45# steel/AISI304

Shaft Seal: Mechanical seal

Bearing: Grease lubrication rolling bearing

Application

Suitable for use with clean water and liquids that are not chemically aggressive towards the pump material. The EN733 centrifugal pumps are recommended for use in water supply, pressure boosting, HVAC, fire-fighting systems, irrigation, industrial applications, and agricultural.

Operating Data

- Flow: up to 220 [m³/h]
- Head: up to 95 [m]
- DN: 32 - 80 [mm]
- Medium: clean water or non-aggressive liquid (free of solids or fiber)

Motors

- Insulation Class: F
- Protection Class: IP55
- Continuous Service: S1
- Power: up to 55 kW
- Frequency: 60 Hz
- Voltage: 220/380/400/440V
- Speed: 3500 rpm

TECHNICAL DATA

60Hz

Model	DN [mm]	Power		Q = Flow													
				gpm	26	40	66	79	106	119	159	185	211	238	317	370	396
				l/min	100	150	250	300	400	450	600	700	800	900	1200	1400	1500
				m ³ /h	6	9	15	18	24	27	36	42	48	54	72	84	90
		kw	hp	H = Head [m]													
TST 32-125/07	50x32	0.75	1	17.5	16.7	15	12	9	-	-	-	-	-	-	-	-	-
TST 32-125/11	50x32	1.1	1.5	22	21	19.7	16.5	14.5	9	-	-	-	-	-	-	-	-
TST 32-160/15	50x32	1.5	2	25.4	23.7	22.5	18.5	15.8	-	-	-	-	-	-	-	-	-
TST 32-160/22	50x32	2.2	3	31	29.6	28.5	24.5	22	15	-	-	-	-	-	-	-	-
TST 32-160/30	50x32	3	4	35	34.3	32.5	28	25.5	19	15	-	-	-	-	-	-	-
TST 32-200/30	50x32	3	4	44.2	42	39.8	35.2	32.2	24.6	19.8	-	-	-	-	-	-	-
TST 32-200/40	50x32	4	5.5	54.5	52	50	45.5	42.3	35	30.3	-	-	-	-	-	-	-
TST 32-250/55	50x32	5.5	7.5	60	59.5	59	55	53	49	46	-	-	-	-	-	-	-
TST 32-250/75	50x32	7.5	10	75	74.5	74.3	73.5	72.5	68.5	67.3	60	-	-	-	-	-	-
TST 32-250/92	50x32	9.2	12.5	79	78.5	78.3	77.5	76.5	72.5	71.3	63	-	-	-	-	-	-
TST 32-250/110	50x32	11	15	90	88	86	82	79	75	72	65	-	-	-	-	-	-
TST 32-250/150	50x32	15	20	97	95	93	89	86	82	79	72	-	-	-	-	-	-
TST32-250/55D	50x32	5.5	7.5	79.5	77	74	70	66	54	42	-	-	-	-	-	-	-
TST32-250/75D	50x32	7.5	10	95	93	91	87	83	75	70	32	-	-	-	-	-	-
TST 40-125/11	65x40	1.1	1.5	14.7	-	-	-	13	11.5	10.1	5.8	-	-	-	-	-	-
TST 40-125/15	65x40	1.5	2	18.1	-	-	-	17	15	13.9	10	6	-	-	-	-	-
TST 40-125/22	65x40	2.2	3	24.5	-	-	-	23.2	21.5	20.2	16	13	8.3	-	-	-	-
TST 40-160/30	65x40	3	4	31.8	-	-	-	29.5	27.5	26.3	21.5	17.5	-	-	-	-	-
TST 40-160/40	65x40	4	5.5	38	-	-	-	36	34	33	28.5	25	20.1	-	-	-	-
TST 40-200/55	65x40	5.5	7.5	46	-	-	-	43.8	41.3	40.1	35	30	-	-	-	-	-
TST 40-200/75	65x40	7.5	10	57	-	-	-	53.6	51.5	50	45	41	36.5	-	-	-	-
TST 40-250/92	65x40	9.2	12.5	64	-	-	-	59	56.5	55	49.5	45	39.8	-	-	-	-
TST 40-250/110	65x40	11	15	78	-	-	-	75	73	72	67	63	56	43	-	-	-
TST 40-250/150	65x40	15	20	88.5	-	-	-	83.5	80.5	79	74	70.5	65	52	-	-	-
TST 40-250/185	65x40	18.5	25	94	-	-	-	89	86	84.5	79.5	76	70.5	57.5	-	-	-
TST 50-125/22	65x50	2.2	3	17	-	-	-	-	-	-	15.4	14	12.8	11.5	6.5	-	-
TST 50-125/30	65x50	3	4	20	-	-	-	-	-	-	18.8	18	17	15.6	11	-	-
TST 50-125/40	65x50	4	5.5	24	-	-	-	-	-	-	23.1	23	21.5	20.3	15.8	11.8	-
TST 50-160/55	65x50	5.5	7.5	32	-	-	-	-	-	-	30.6	30	28	26.6	20.5	14.8	-
TST 50-160/75	65x50	7.5	10	40	-	-	-	-	-	-	38	37	36	34.4	29	24	21
TST 50-200/92	65x50	9.2	12.5	50.5	-	-	-	-	-	-	46.8	45	43	40.9	32.5	26.7	-
TST 50-200/110	65x50	11	15	57.5	-	-	-	-	-	-	53.5	52	50	47.5	40	34	29
TST 50-200/150	65x50	15	20	62	-	-	-	-	-	-	58	56.5	54.5	52	44.5	39	35.5
TST 50-250/150	65x50	15	20	68.5	-	-	-	-	-	-	64	63	61.5	59	50	41	-

TECHNICAL DATA

60Hz

Model	DN [mm]	Power		Q = Flow																
				gpm 0	26	40	66	79	106	119	159	185	211	238	317	370	396	476	529	608
				l/min 0	100	150	250	300	400	450	600	700	800	900	1200	1400	1500	1800	2000	2300
				m ³ /h 0	6	9	15	18	24	27	36	42	48	54	72	84	90	108	120	138
		kw	hp	H = Head [m]																
TST 50-250/185	65x50	18.5	25	79	-	-	-	-	-	-	75.8	74.8	74	71.5	63.5	55.5	47	-	-	-
TST 50-250/220	65x50	22	30	89.5	-	-	-	-	-	-	86	85.3	84	81.5	73.5	63.5	57	-	-	-
TST 65-125/40	80x65	4	5.5	19	-	-	-	-	-	-	-	-	17.3	16.8	14.5	13	11.8	-	-	-
TST 65-125/55	80x65	5.5	7.5	23	-	-	-	-	-	-	-	-	21.3	20.9	19	17.5	16.7	13.7	-	-
TST 65-125/75	80x65	7.5	10	27	-	-	-	-	-	-	-	-	26	25.6	24.5	23	22.5	20	18	-
TST 65-160/92	80x65	9.2	12.5	33	-	-	-	-	-	-	-	-	-	31.5	30	28	27.1	24	21.5	-
TST 65-160/110	80x65	11	15	36	-	-	-	-	-	-	-	-	-	34.5	33	31.5	30.8	28	25.5	-
TST 65-160/150	80x65	15	20	42	-	-	-	-	-	-	-	-	-	41	40	38.5	37.8	35	33	29.5
TST 65-200/150	80x65	15	20	45	-	-	-	-	-	-	-	-	-	45.5	43	41	40.2	36.5	34	-
TST 65-200/185	80x65	18.5	25	52	-	-	-	-	-	-	-	-	-	52.3	51	49	48.2	44.5	42	-
TST 65-200/220	80x65	22	30	59	-	-	-	-	-	-	-	-	-	59.5	58	56	55	52	49.5	44.5
TST 65-250/220	80x65	22	30	64.8	-	-	-	-	-	-	-	-	-	64.7	62	60	58.5	53	50	-
TST 65-250/300	80x65	30	40	80	-	-	-	-	-	-	-	-	-	79.8	77.5	75.5	74.5	70	66	58
TST 65-250/370	80x65	37	50	92	-	-	-	-	-	-	-	-	-	90.5	88.5	87	85	80.5	78	68

Model	DN [mm]	Power		Q = Flow							
				gpm 0	264	396	529	634	793	881	925
				l/min 0	1000	1500	2000	2400	3000	3333	3500
				m ³ /h 0	60	90	120	144	180	200	210
		kw	hp	H = Head [m]							
TST 80-160/110	100x80	11	15	28	27	27.3	24.5	21.1	16	-	-
TST 80-160/150	100x80	15	20	34	32.6	32.5	30.2	27	22.1	18.5	16.7
TST 80-160/185	100x80	18.5	25	39	38.5	38	36.7	33.6	28.8	25.3	23.5
TST 80-160/220	100x80	22	30	44	43.5	43	41.7	38.6	33.8	30.3	28.5
TST 80-200/220	100x80	22	30	48	47.7	47.5	43.5	39.2	32.5	27.2	24.5
TST 80-200/300	100x80	30	40	60	59.7	59.5	57	53.1	47	42.7	40.5
TST 80-250/370	100x80	37	50	71.5	70.9	70.5	65.5	59.3	51	43.2	38.5
TST 80-250/450	100x80	45	60	88	86.7	86	83.6	78.5	70.5	60	51
TST 80-250/550	100x80	55	75	94.5	94.5	94.5	91.8	87	79.5	72.1	68.3

MATERIAL DESCRIPTION

Parts List

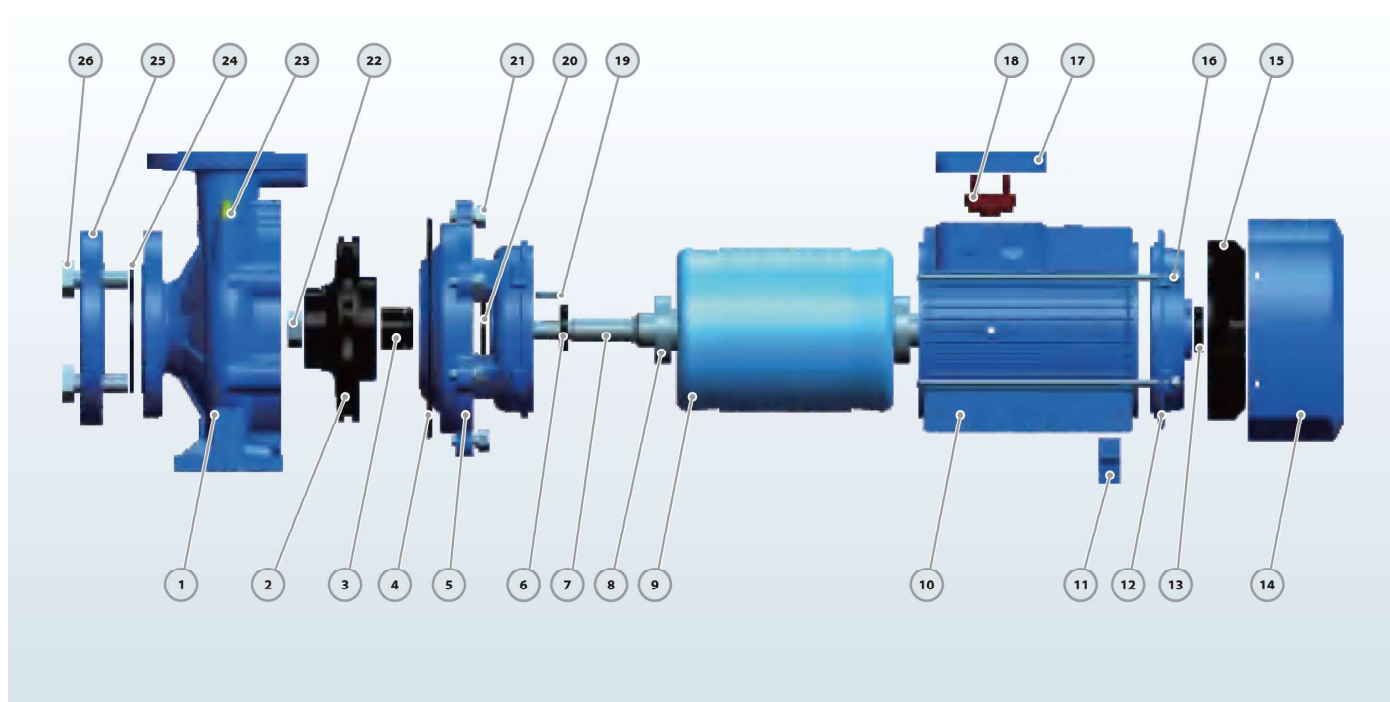

No.	Description	Material	No.	Description	Material	No.	Description	Material
1	Pump Case	Cast iron	10	Motor Case	Aluminum	19	Impeller Key	Iron
2	Impeller	SS304 / Cast iron	11	Support Foot	Plastic	20	Water Deflector	Rubber
3	Mechanical Seal	SiC / Carbon / SS304	12	Back Cover	Cast iron	21	Connection Bolt	Steel
4	O-ring	Rubber	13	Reinforced Seal	Rubber	22	Impeller Nut	Galvanized Steel
5	Connection	Cast iron	14	Fan Cover	Aluminum	23	Release Valve	Brass
6	Reinforced Seal	Rubber	15	Fan	Plastic	24	Gasket	Rubber
7	Shaft	SS304 / 45# Steel	16	Through Bolt	Steel	25	Counter Flange	Galvanized Cast iron
8	Bearing	Ball Bearing	17	Terminal Box	Aluminum	26	Flange Bolt	Steel
9	Wound Stator/ Rotor	Silicon Steel / Copper	18	Terminal Board	Plastic			

DIMENSIONS & WEIGHT

60Hz

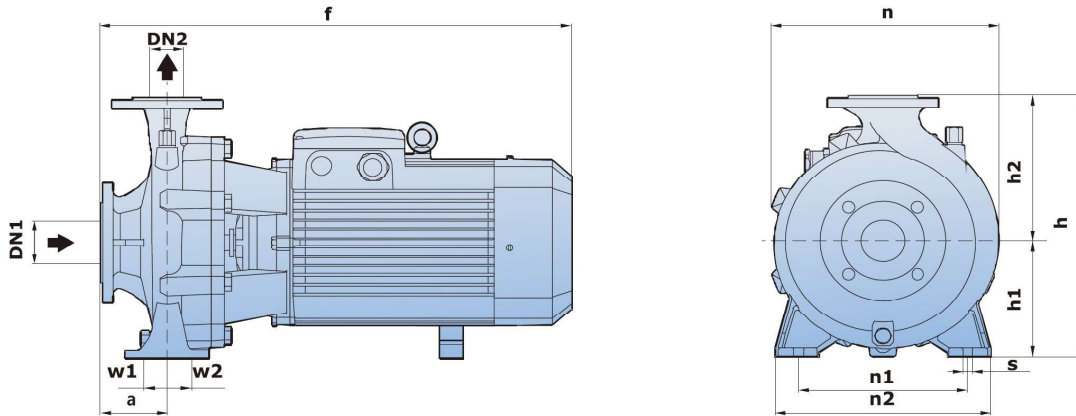

Model	Dimensions [mm]													Weight [kg] 3~			
	DN1	DN2	a	f	h	h1	h2	n	n1	n2	w1	w2	s				
TST 32-125/7	50	32	80	435	255	114	141	202	140	190	35	35	15	24			
TST 32-125/11															25		
TST 32-160/15																34	
TST 32-160/22			83	435	295	133	162	245	190	245	35	35	15				39
TST 32-160/30																	
TST 32-200/30			82	490	342	161	181	265	190	240	49	49	16				52
TST 32-200/40																	
TST 32-250/55			88	590	405	186	219	333	250	328	49	49	16				66
TST 32-250/75																	
TST 32-250/92			88	590	405	186	219	333	250	328	49	49	16				80
TST 32-250/110																	
TST 32-250/150			94	712	415	186	229	327	250	327	49	49	16				125
TST 32-250/55D-75D	160	610												362			
TST 40-125/11			65	40	82	440	260	116	144	220	160	212	37		37		15
TST 40-125/15	29																
TST 40-125/22		34															
TST 40-160/30					80	490	305	135	170	250	190	241	49	49	15	48	
TST 40-160/40																	50
TST 40-200/55-75					102	560	345	162	193	282	214	267	49	49	15	66 / 73	
TST 40-250/92																	100
TST 40-250/110					94	712	415	186	229	327	250	327	49	49	15	116	
TST 40-250/150																	146
TST 40-250/185					94	712	415	186	229	327	250	327	49	49	15	155	
TST 50-125/22																	41
TST 50-125/30					65	50	102	525	305	135	170	263	190	245	37	37	
TST 50-125/40			52														

DIMENSIONS & WEIGHT

60Hz

Model	Dimensions [mm]													Weight [kg] 3~
	DN1	DN2	a	f	h	h1	h2	n	n1	n2	w1	w2	s	
TST 50-160/55-75	65	50	110	560	348	164	193	270	212	262	37	37	15	64 / 71
TST 50-200/92			104	722	392	186	206	307	232	310				90
TST 50-200/110			102	720	416	186	230	330	250	327				106
TST 50-200/150			102	720	416	186	230	330	250	327				145
TST 50-250/150-185-220	80	65	104	580	345	162	193	275	212	280	49	49		148/153/183
TST 65-125/40			104	580	345	162	193	275	212	280				56
TST 65-125/55-75			110	730	425	186	239	330	232	309				68 / 74
TST 65-160/92			110	730	425	186	239	330	232	309				90
TST 65-160/110			111	740	425	186	239	330	232	309				106
TST 65-160/150	100	80	111	740	425	186	239	330	232	309	49	49		134
TST 65-200/150-185-220			111	740	425	186	239	330	232	309				140/145/185
TST 80-160/110			88	750	435	186	250	330	255	332				113
TST 80-160/150-185-220	88	750	435	186	250	330	255	332	113	143/150/183				

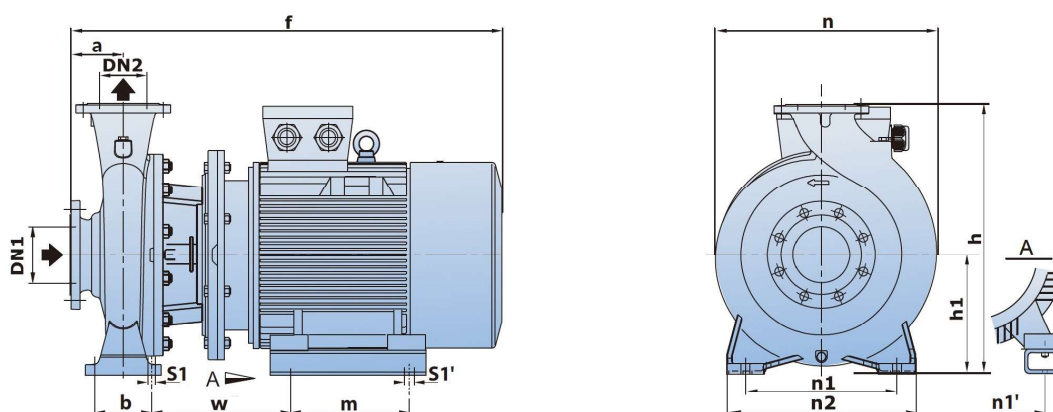

Model	Dimensions [mm]															Weight [kg] 3~
	DN1	DN2	a	f	h	h1	n	n1	n1'	n2	b	w	m	s1	s1'	
TST 65-250/220	80	65	116	870	420	180	369	280	279	360	120	237	241	18	15	214
TST 65-250/300	80	65	116	990	420	180	369	280	318	360	120	278	305	18	18	265
TST 65-250/370	80	65	116	990	420	180	369	280	318	360	120	278	305	18	18	285
TST 80-200/220	100	80	125	880	460	250	360	280	279	345	95	251	241	14	15	211
TST 80-200/300	100	80	125	950	460	250	360	280	318	345	95	242	305	14	18	262
TST 80-250/370	100	80	125	950	535	250	410	315	318	400	120	229	305	18	18	289
TST 80-250/450	100	80	125	980	535	250	410	315	356	400	120	235	311	18	18	362
TST 80-250/550	100	80	125	1160	535	250	410	315	406	400	120	373	349	18	24	441

PERFORMANCE CURVES

60Hz

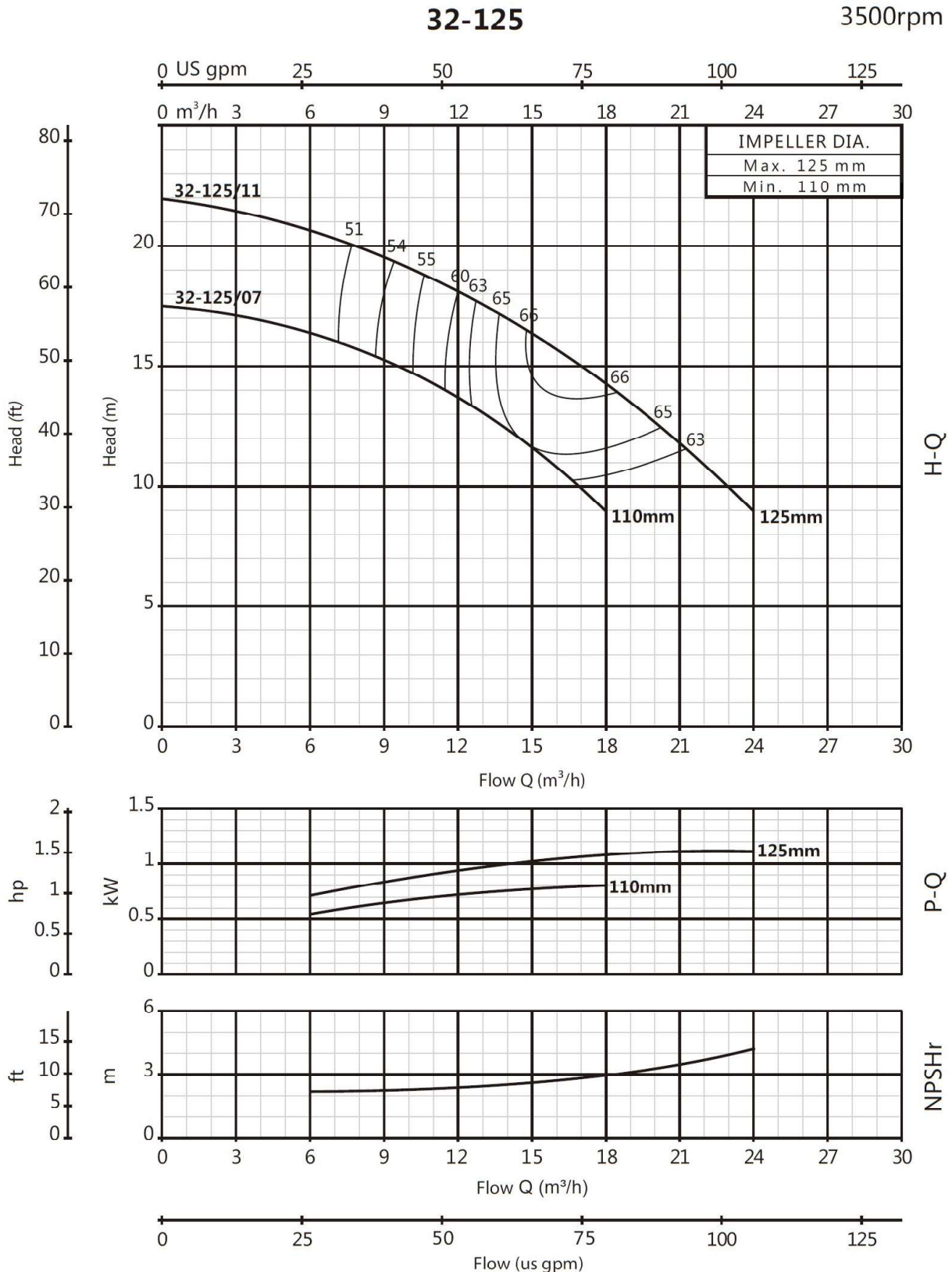

PERFORMANCE CURVES

60Hz

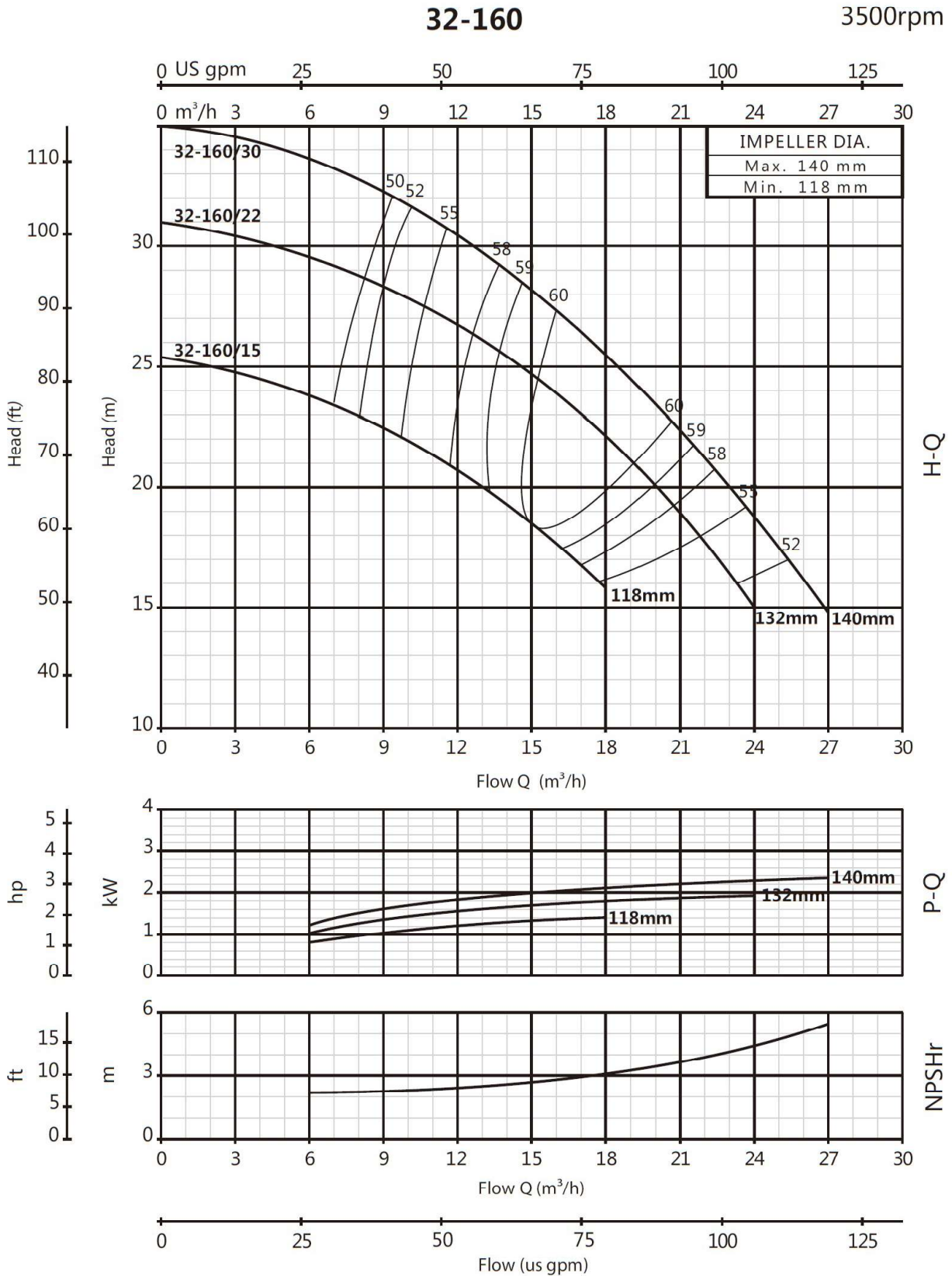

PERFORMANCE CURVES

60Hz

32-200

3500rpm

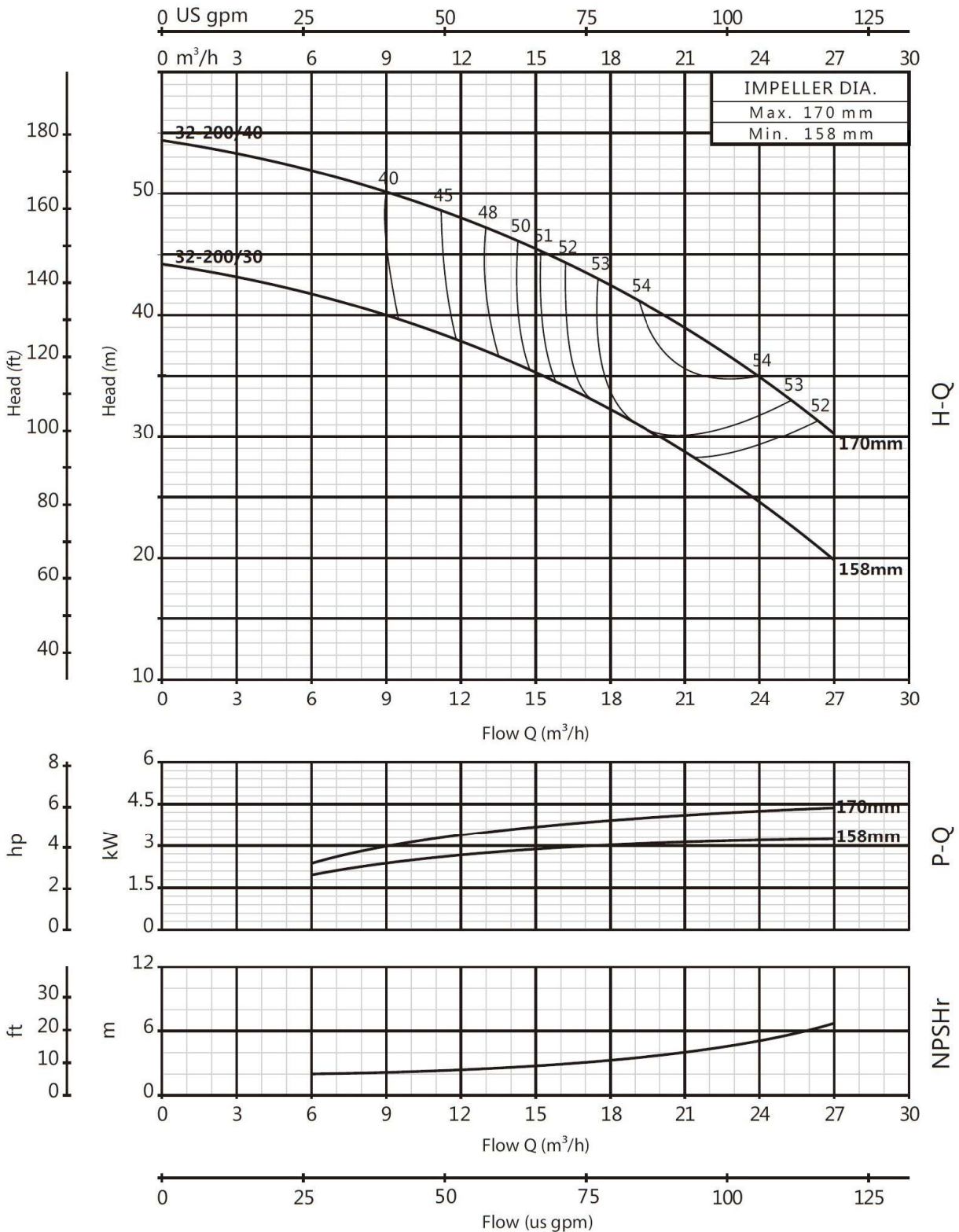

PERFORMANCE CURVES

60Hz

32-250

3500rpm

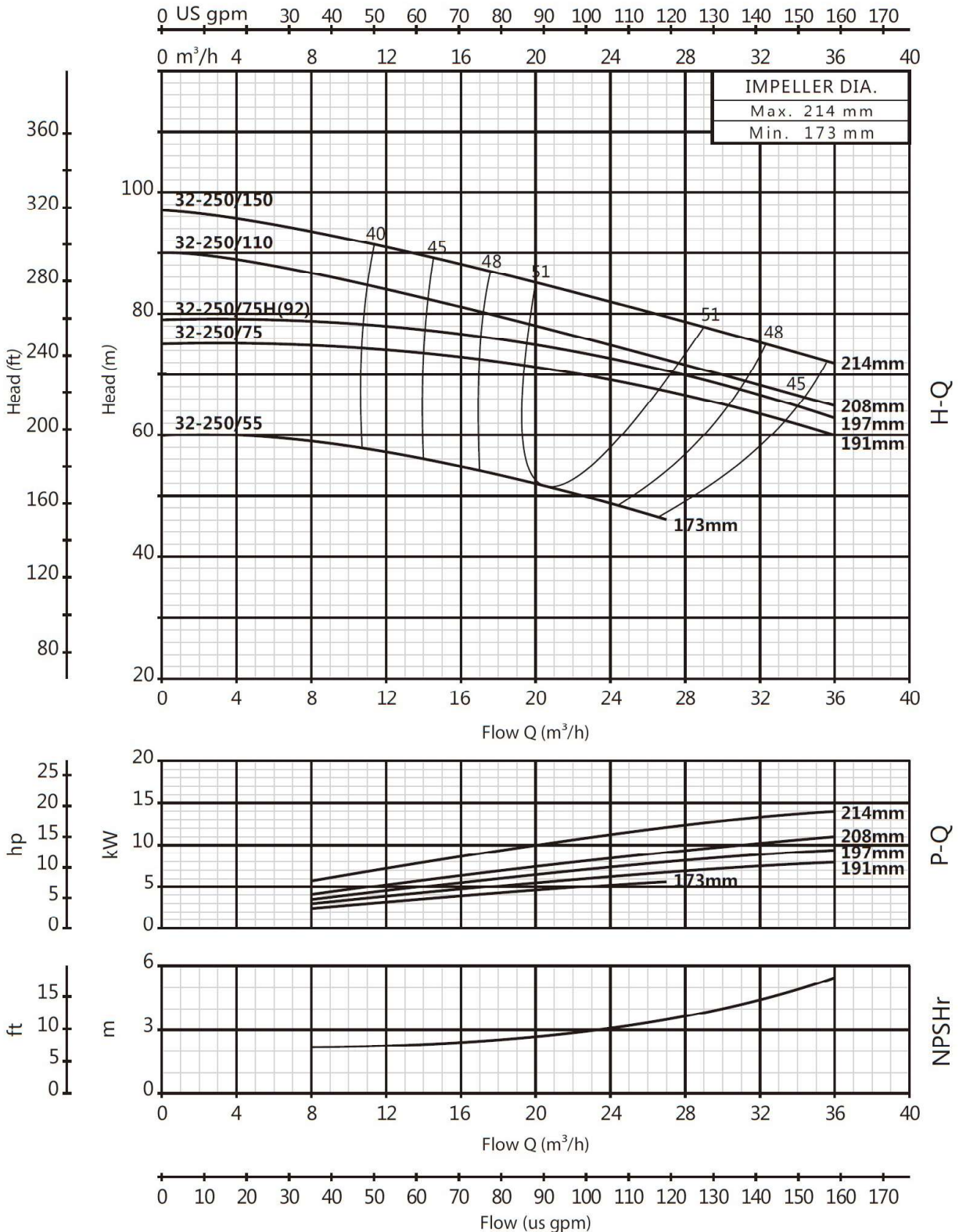

PERFORMANCE CURVES

60Hz

32-250D

3500rpm

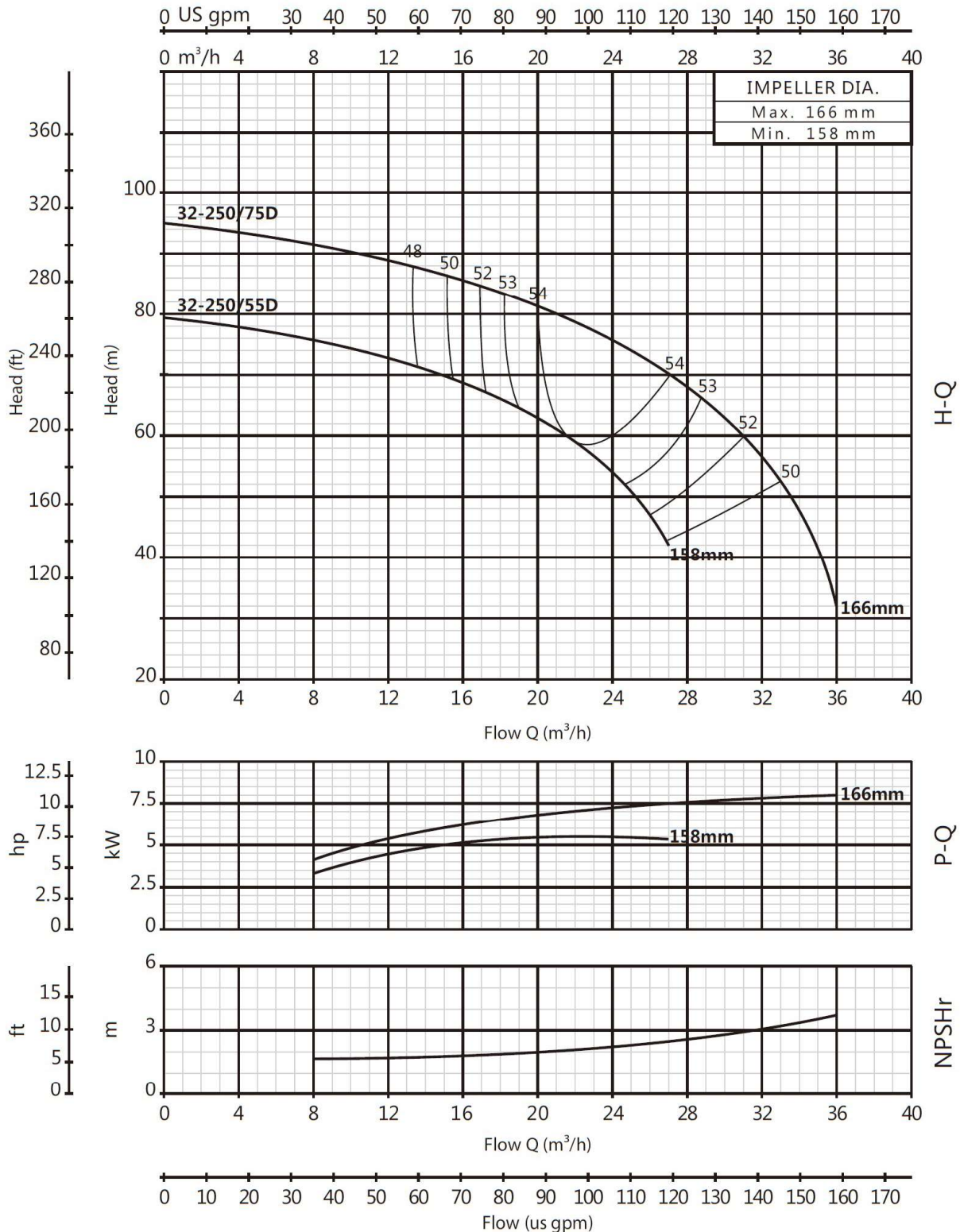

PERFORMANCE CURVES

60Hz

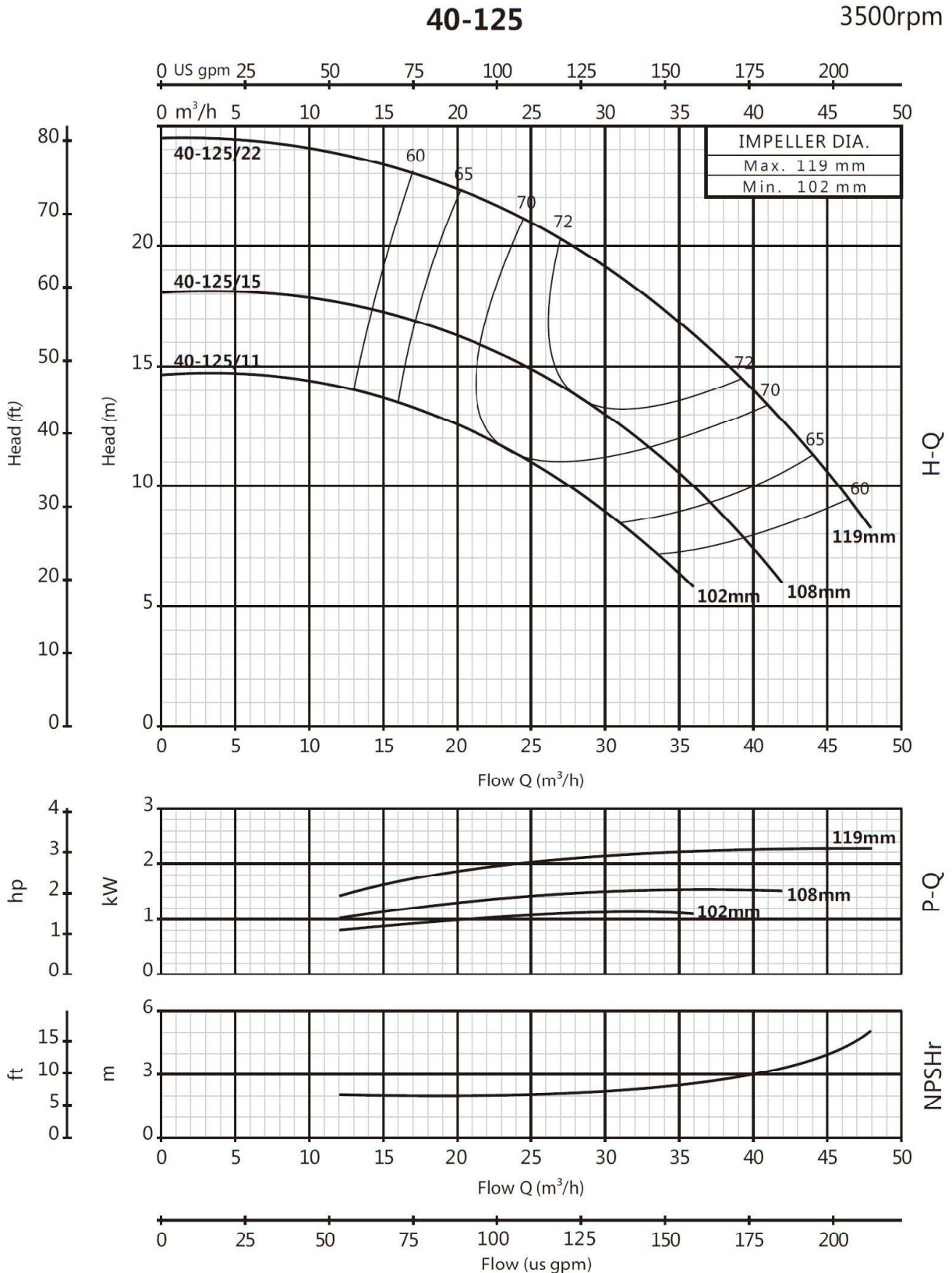

PERFORMANCE CURVES

60Hz

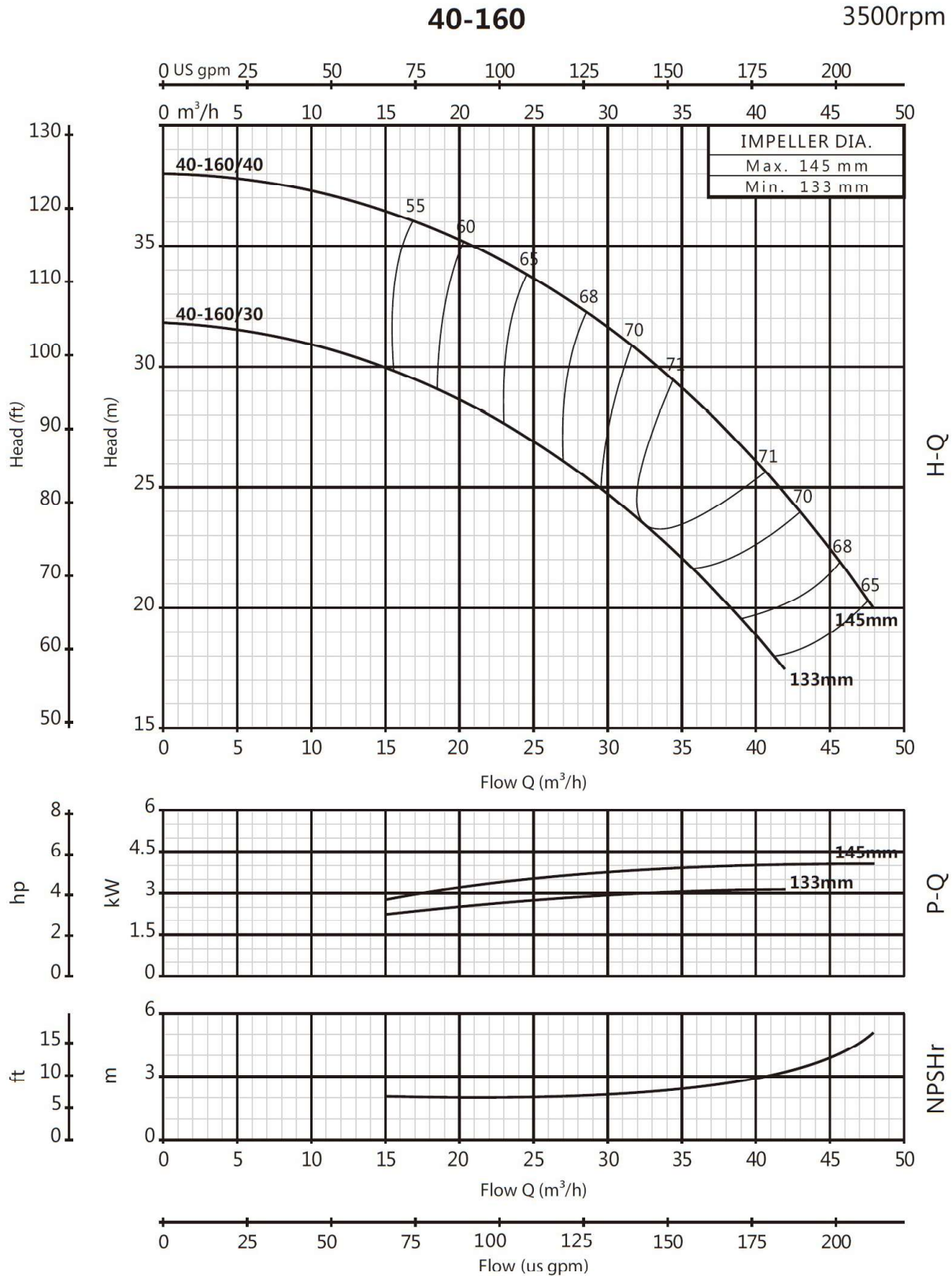

PERFORMANCE CURVES

60Hz

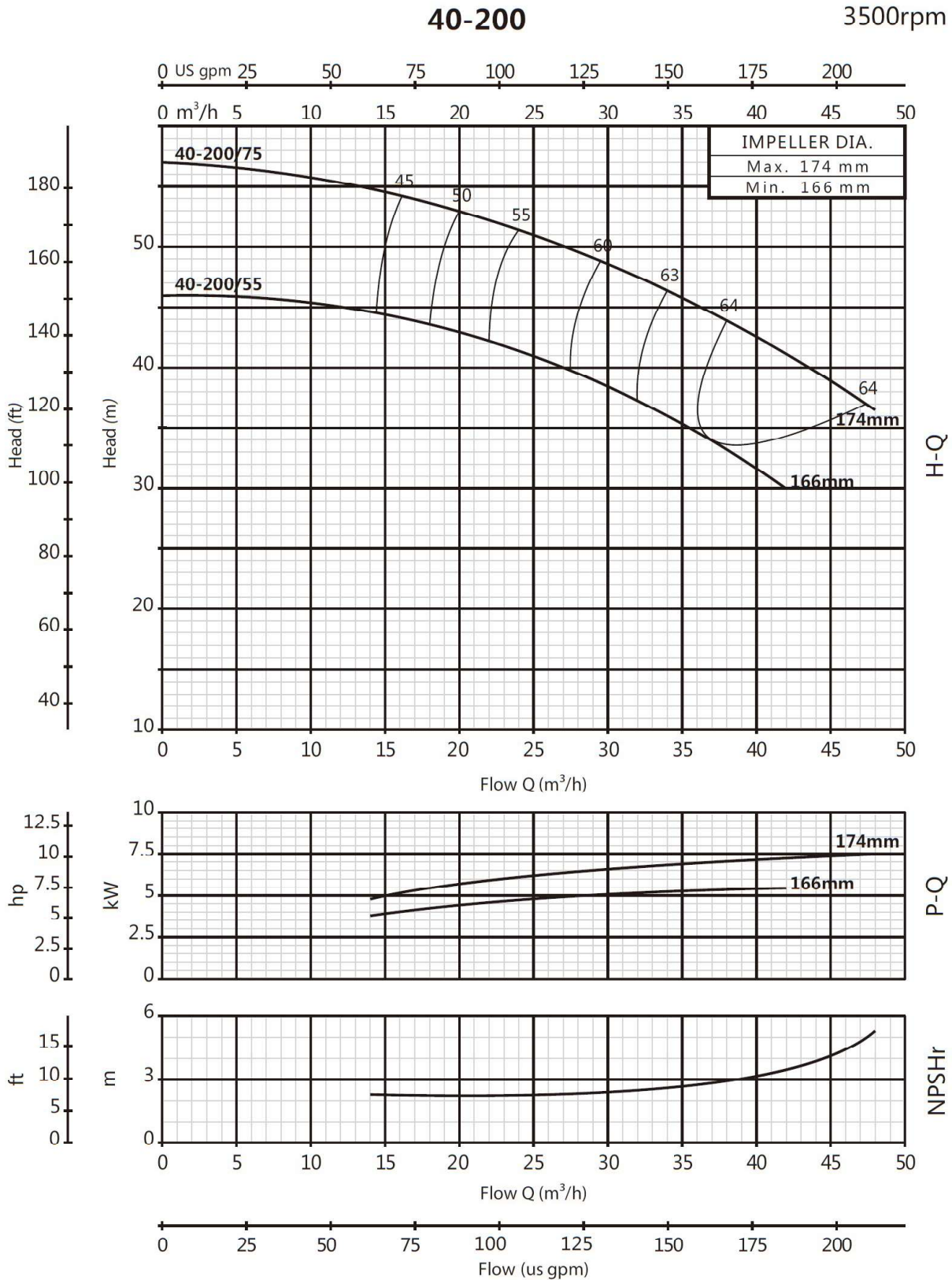

PERFORMANCE CURVES

60Hz

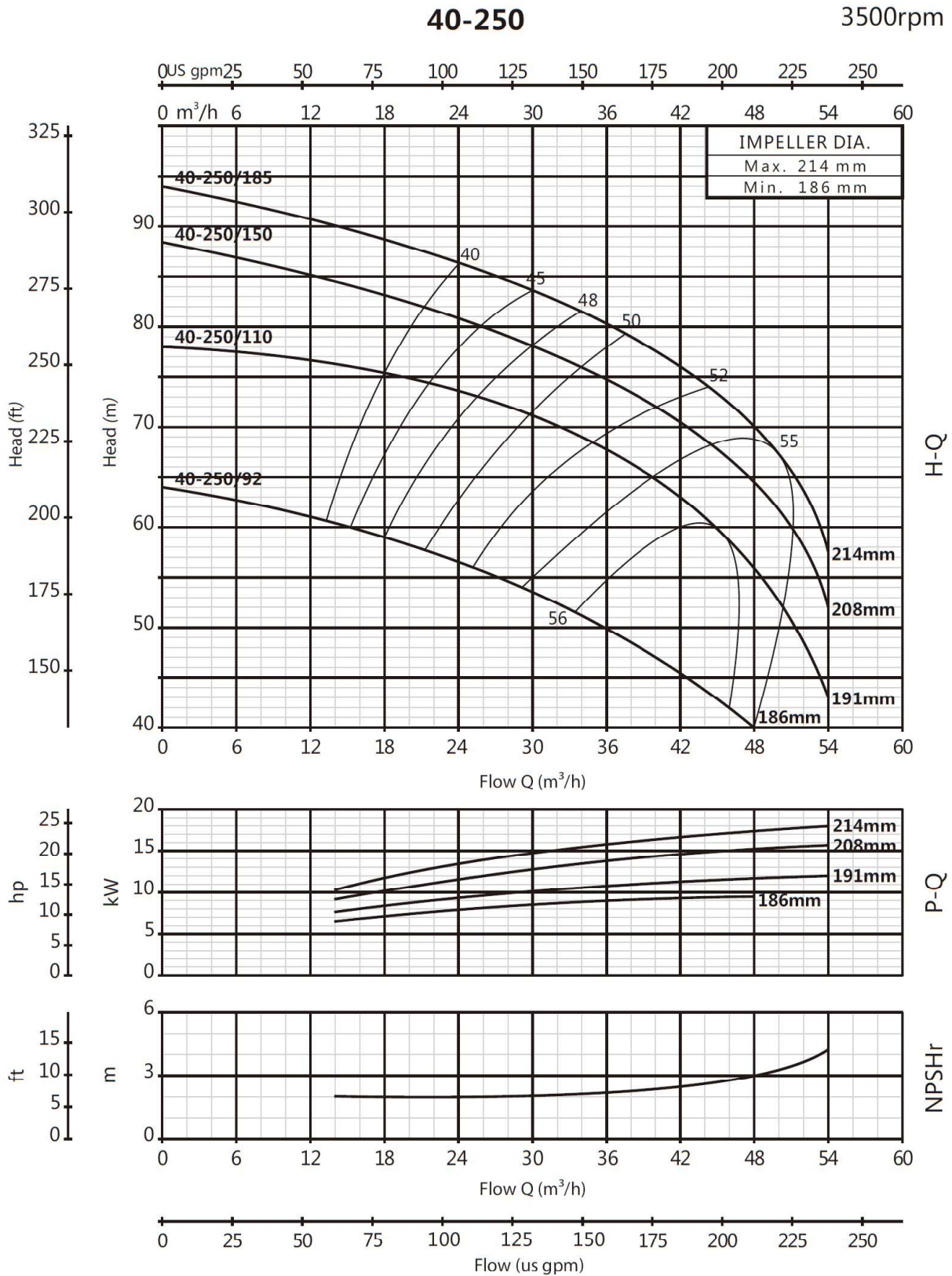

PERFORMANCE CURVES

60Hz

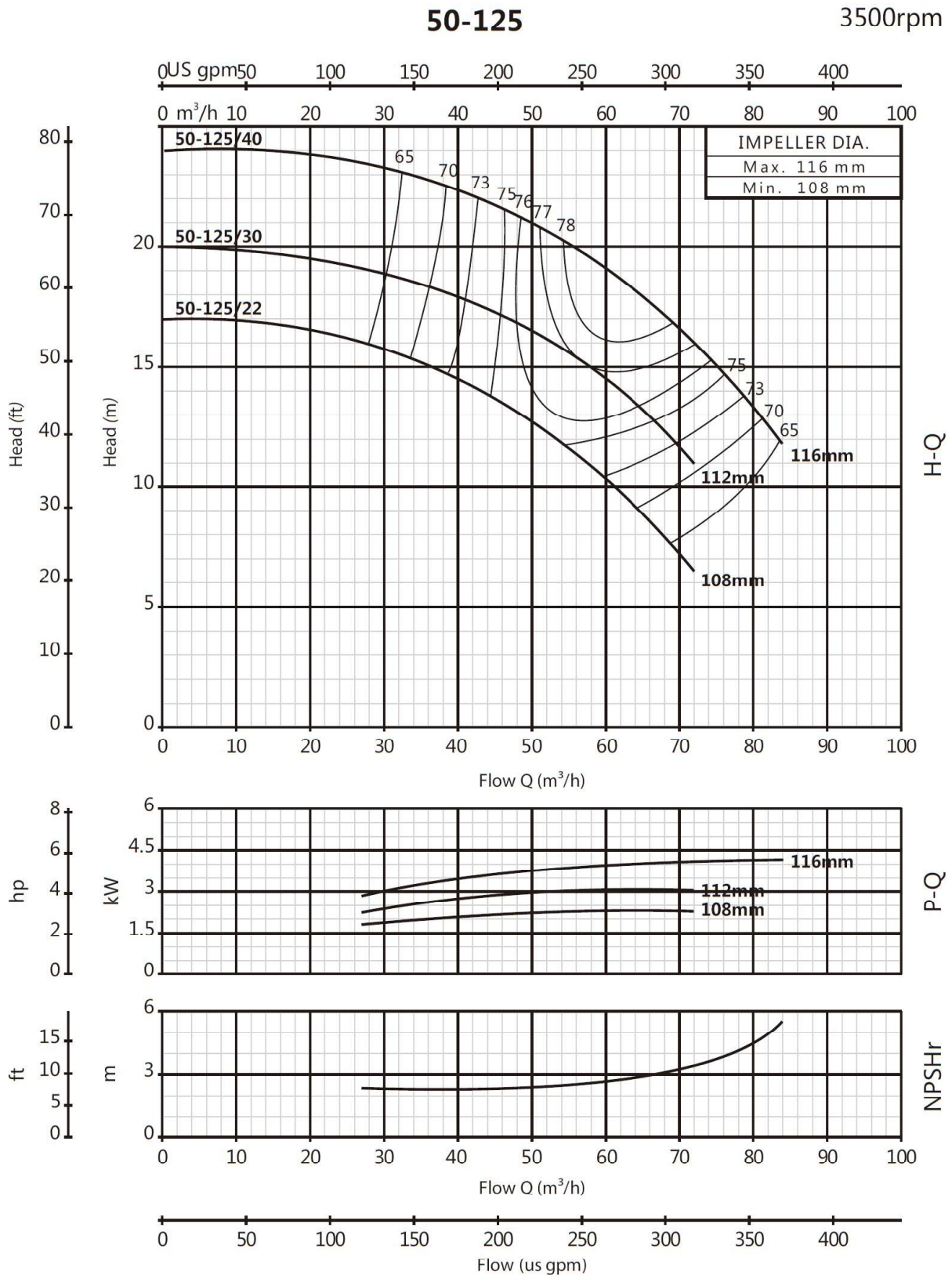

PERFORMANCE CURVES

60Hz

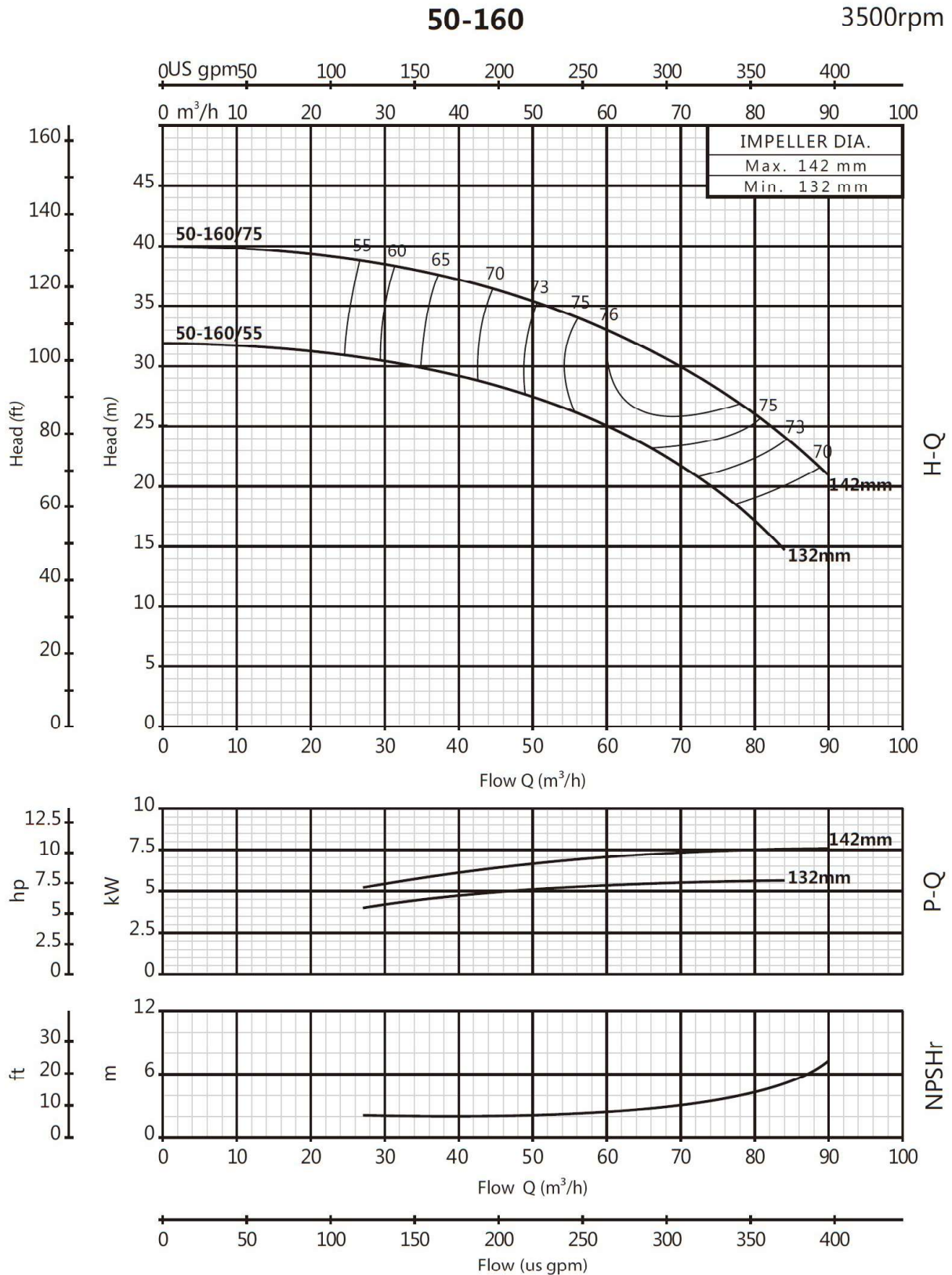

PERFORMANCE CURVES

60Hz

50-200

3500rpm

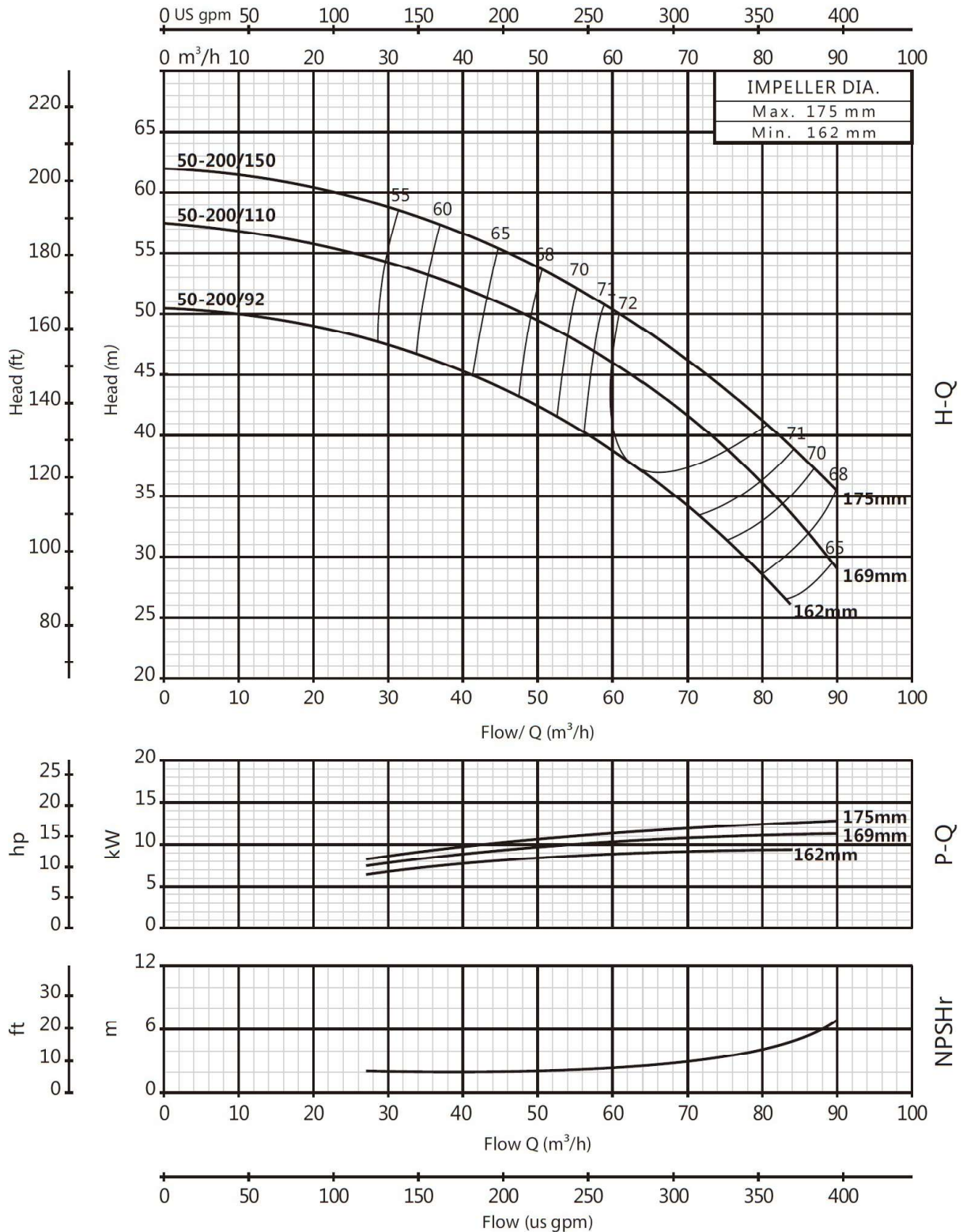

PERFORMANCE CURVES

60Hz

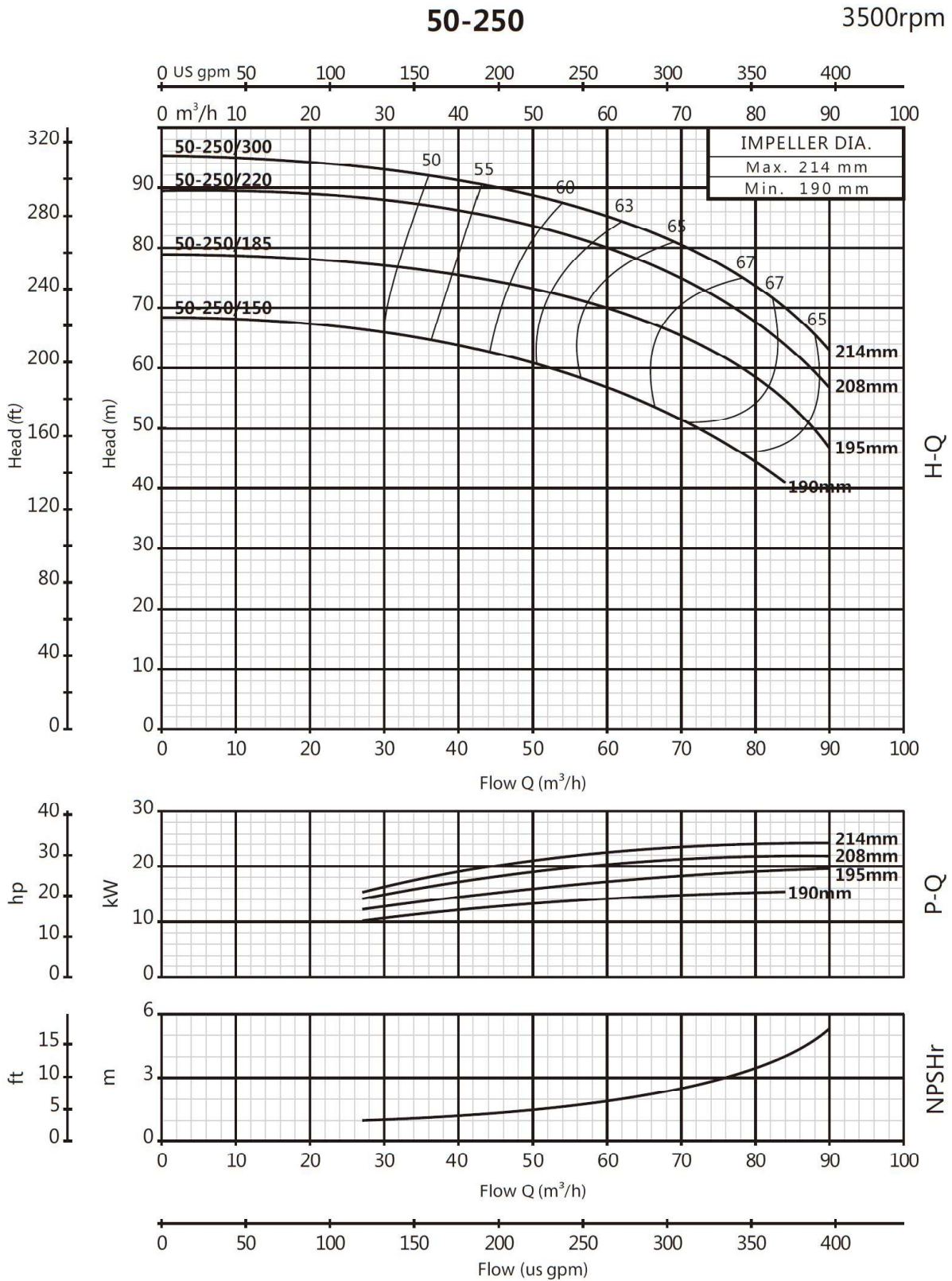

PERFORMANCE CURVES

60Hz

65-125

3500rpm

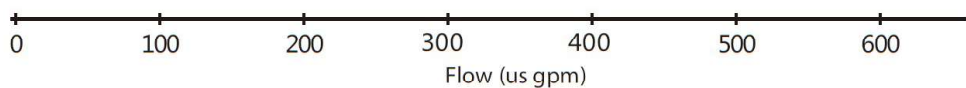
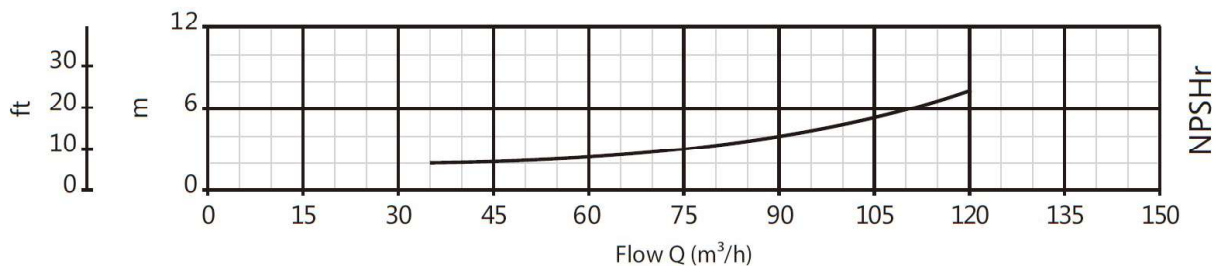
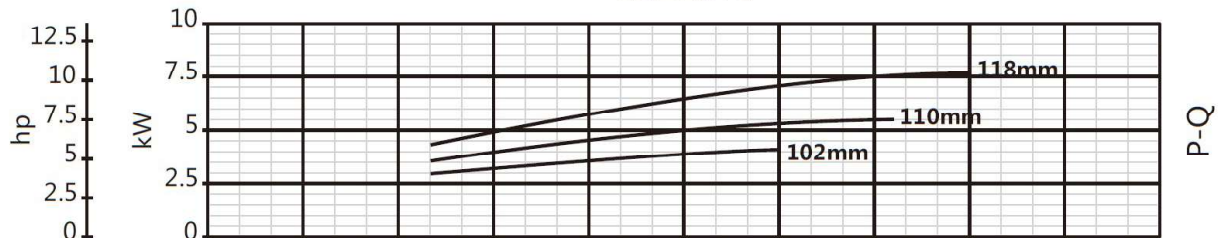
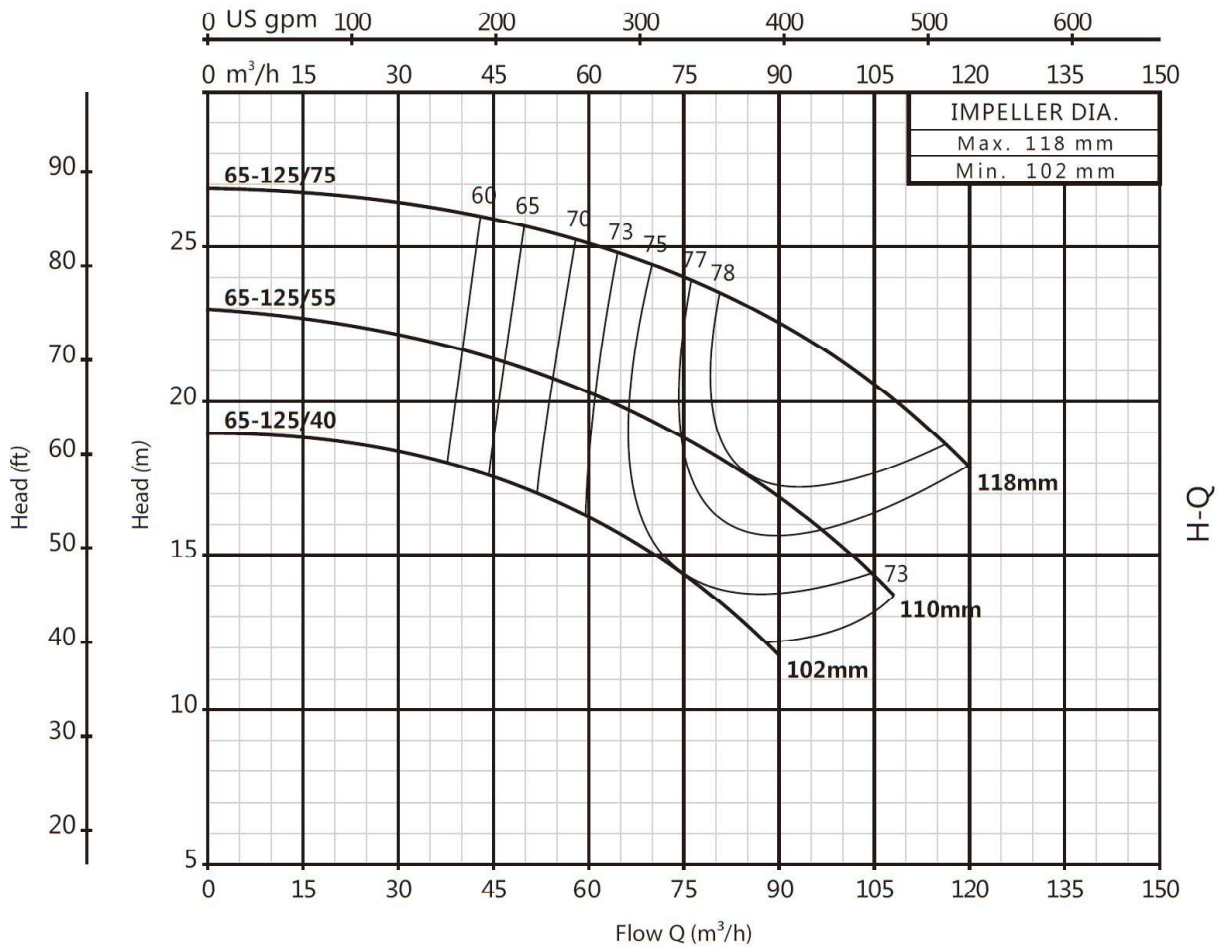

PERFORMANCE CURVES

60Hz

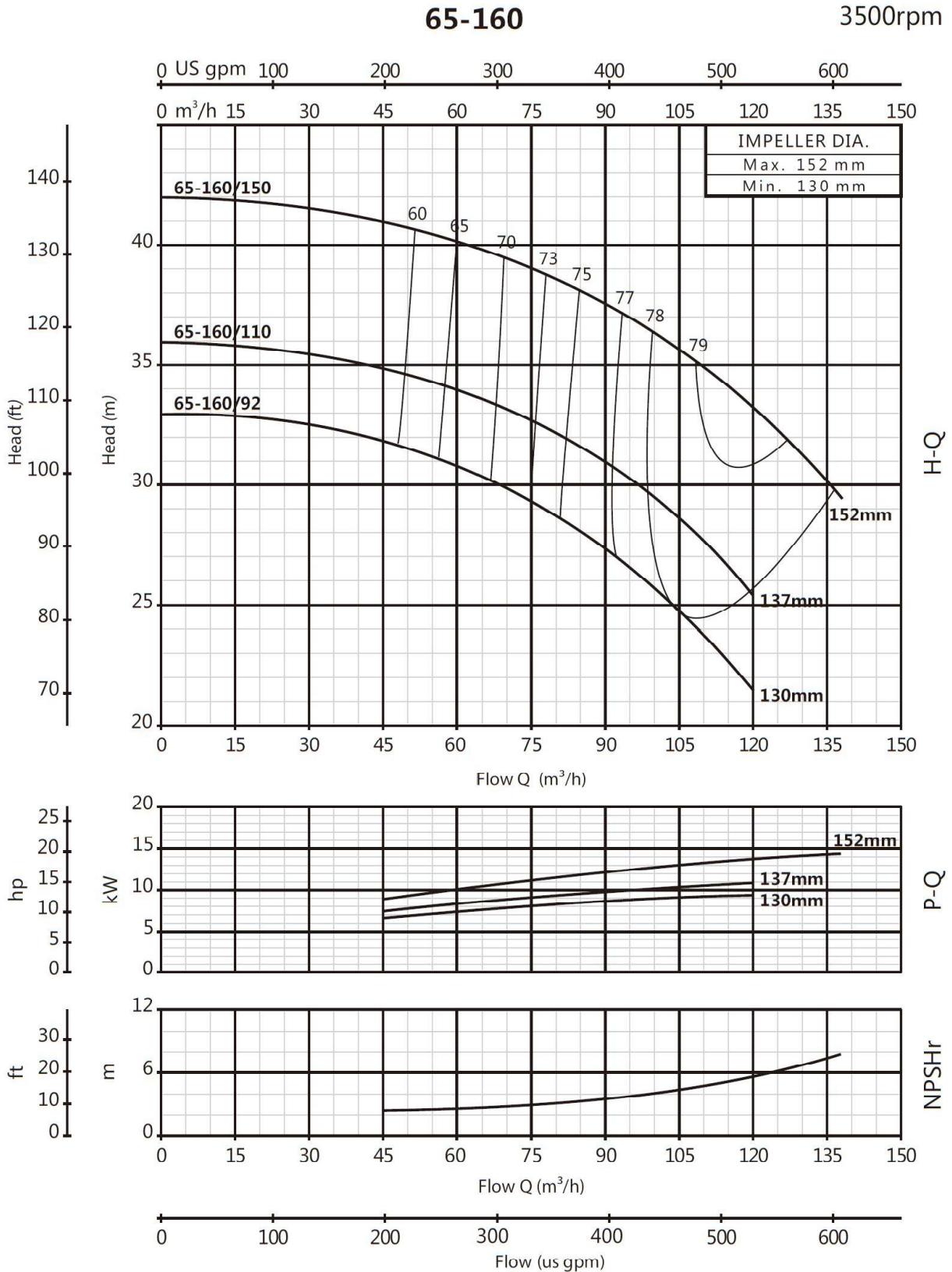

PERFORMANCE CURVES

60Hz

65-200

3500rpm

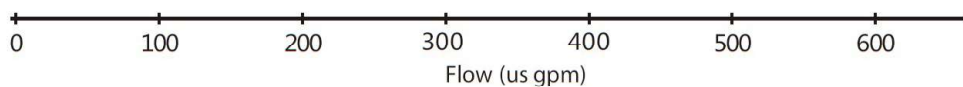
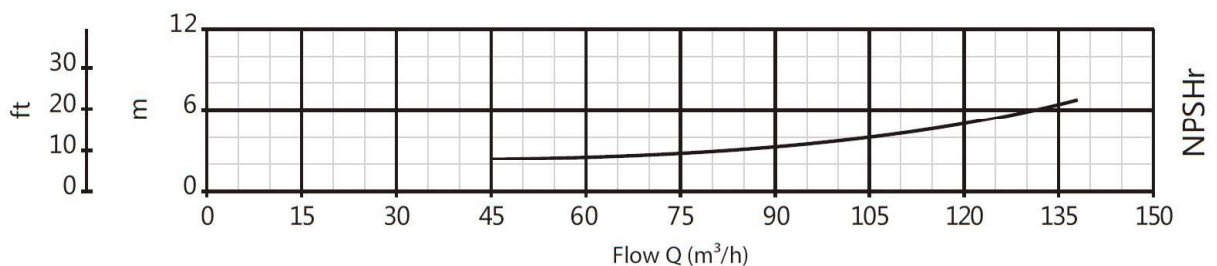
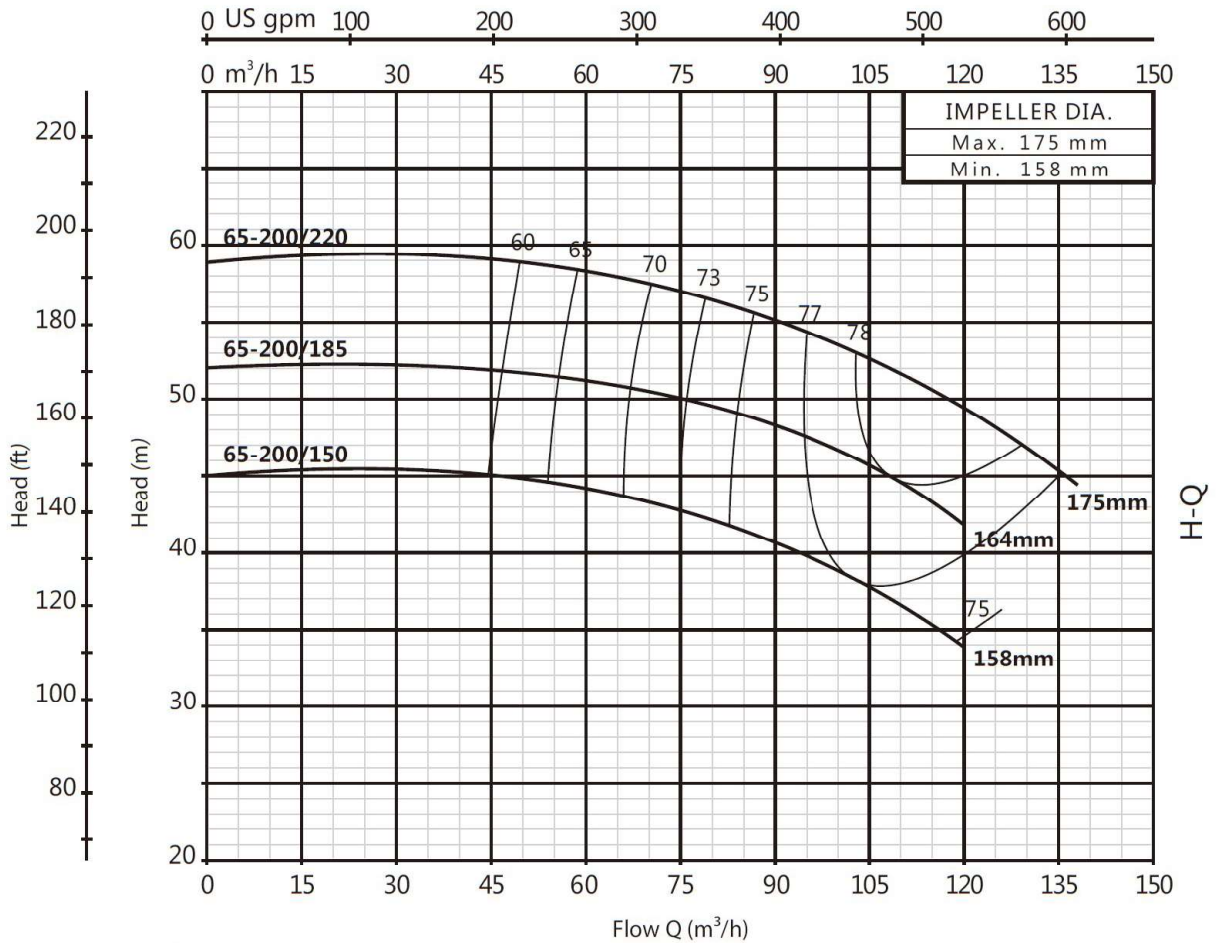

PERFORMANCE CURVES

60Hz

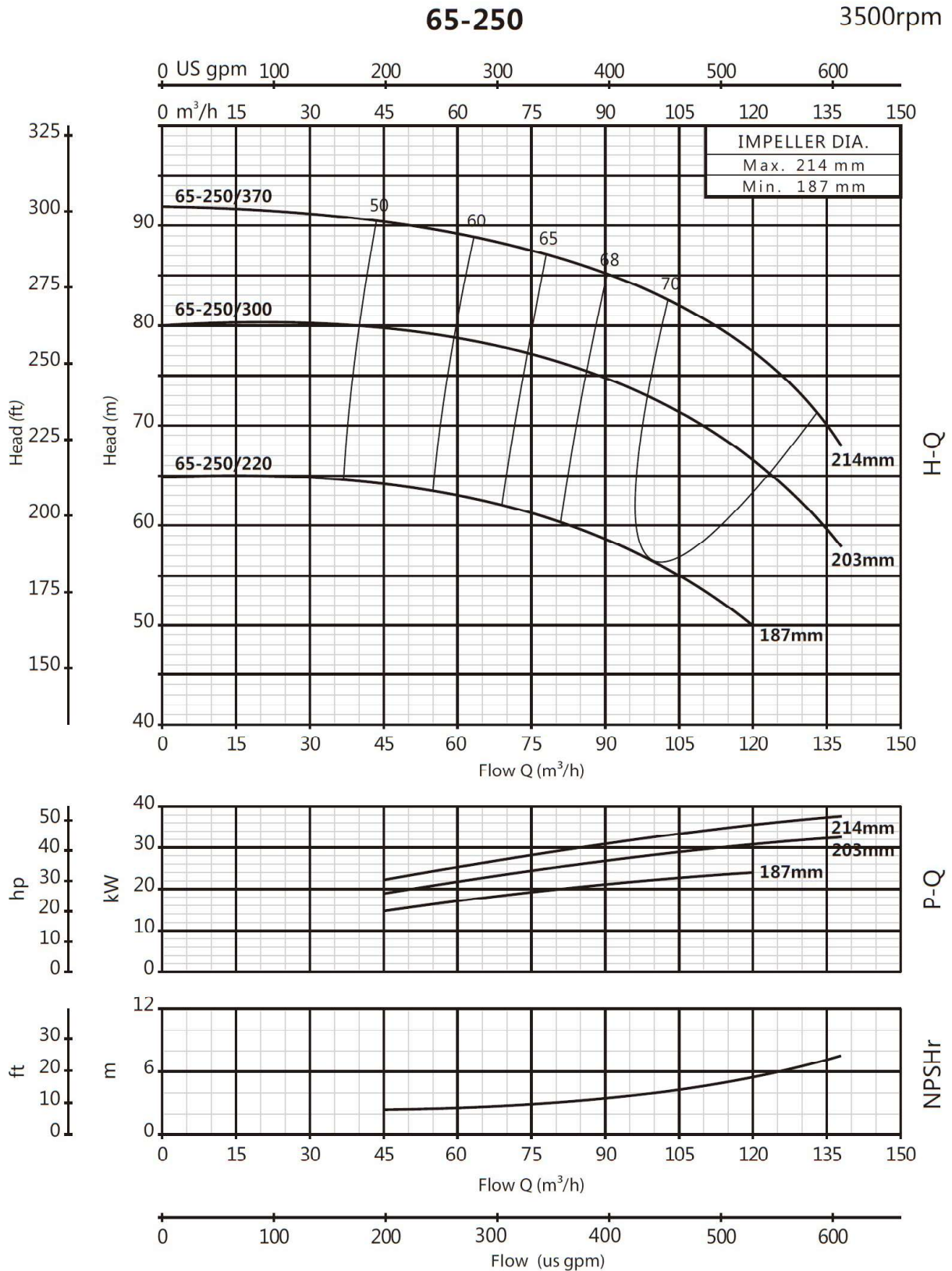

PERFORMANCE CURVES

60Hz

80-160

3500rpm

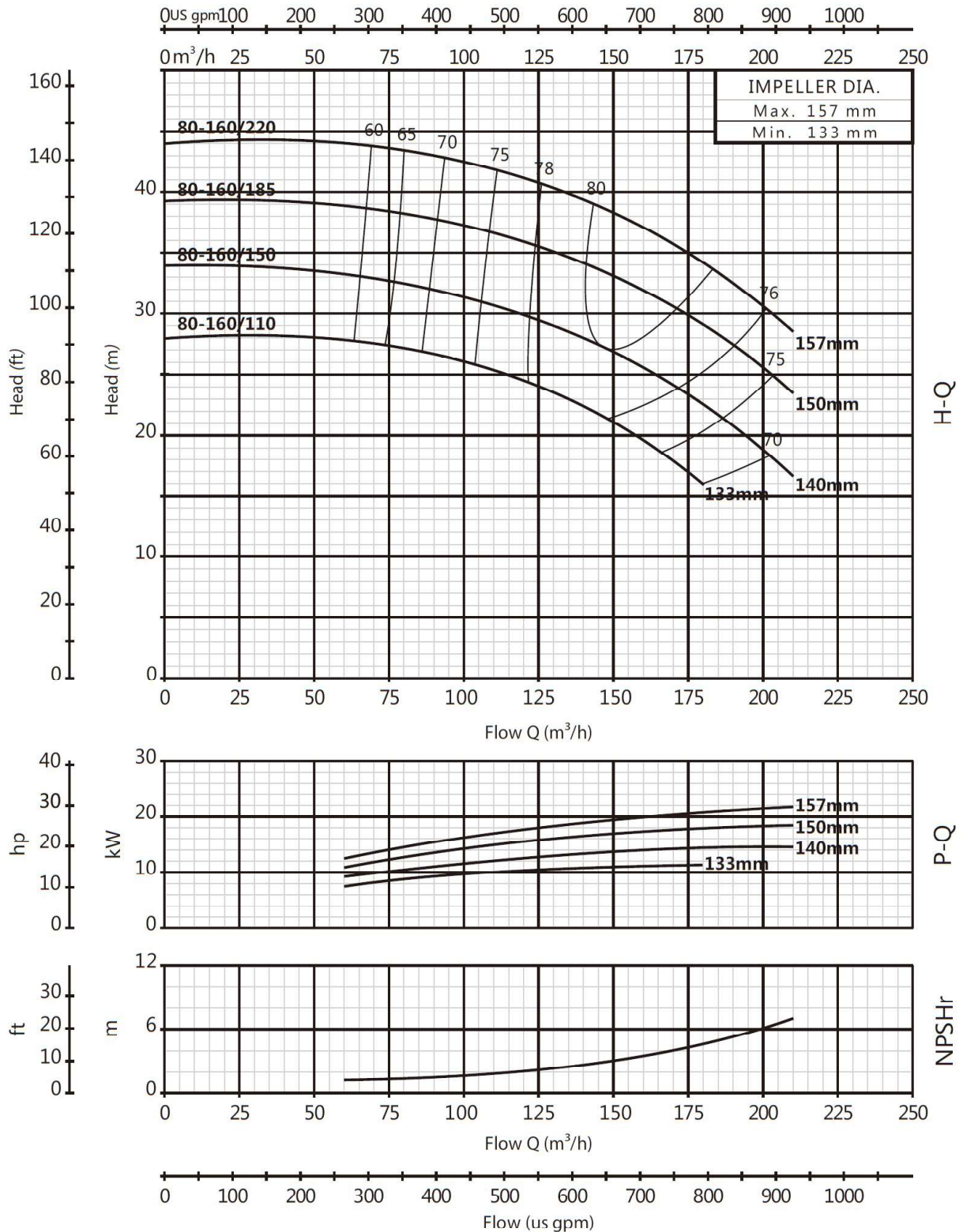

PERFORMANCE CURVES

60Hz

80-200

3500rpm

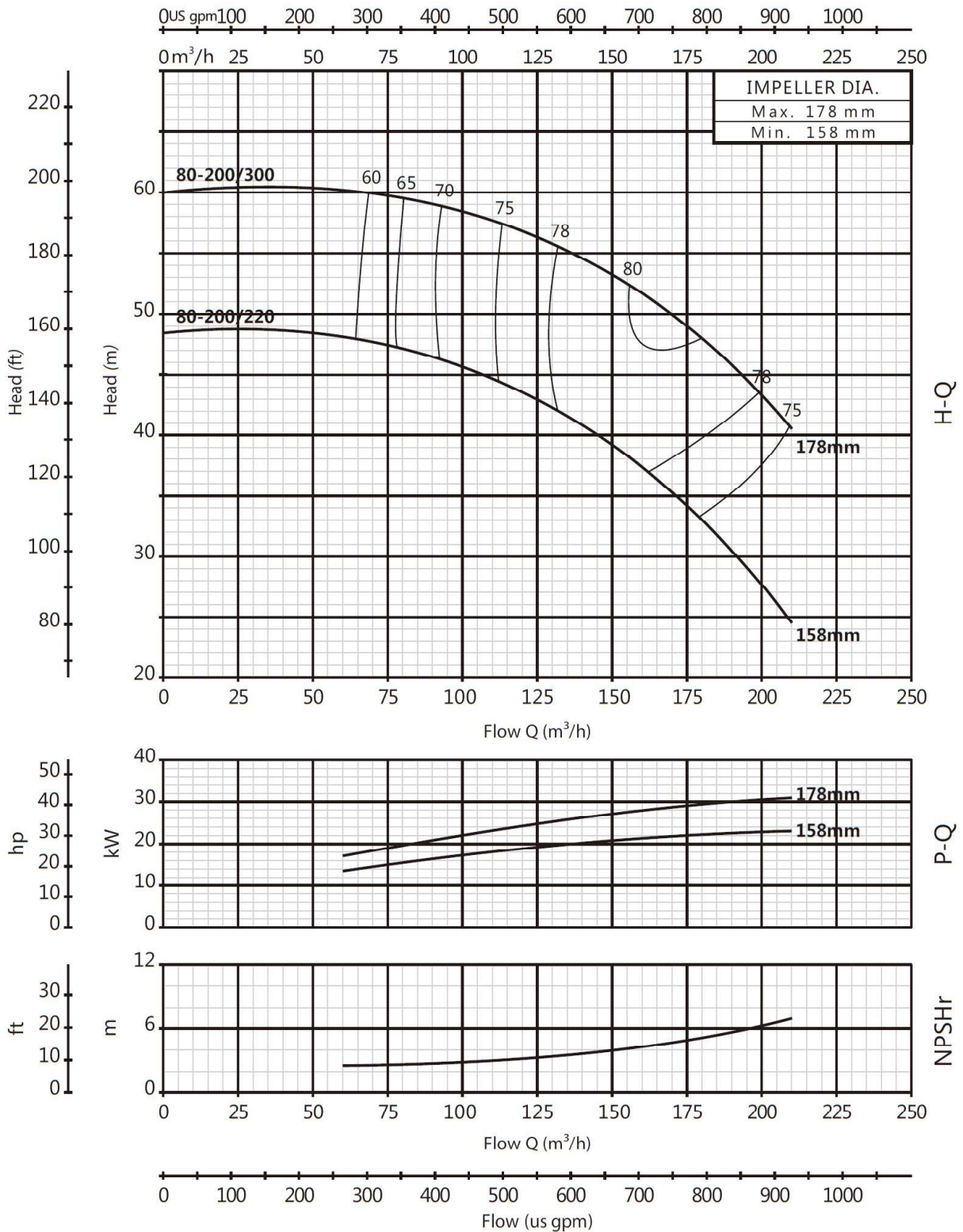

PERFORMANCE CURVES

60Hz

80-250

3500rpm

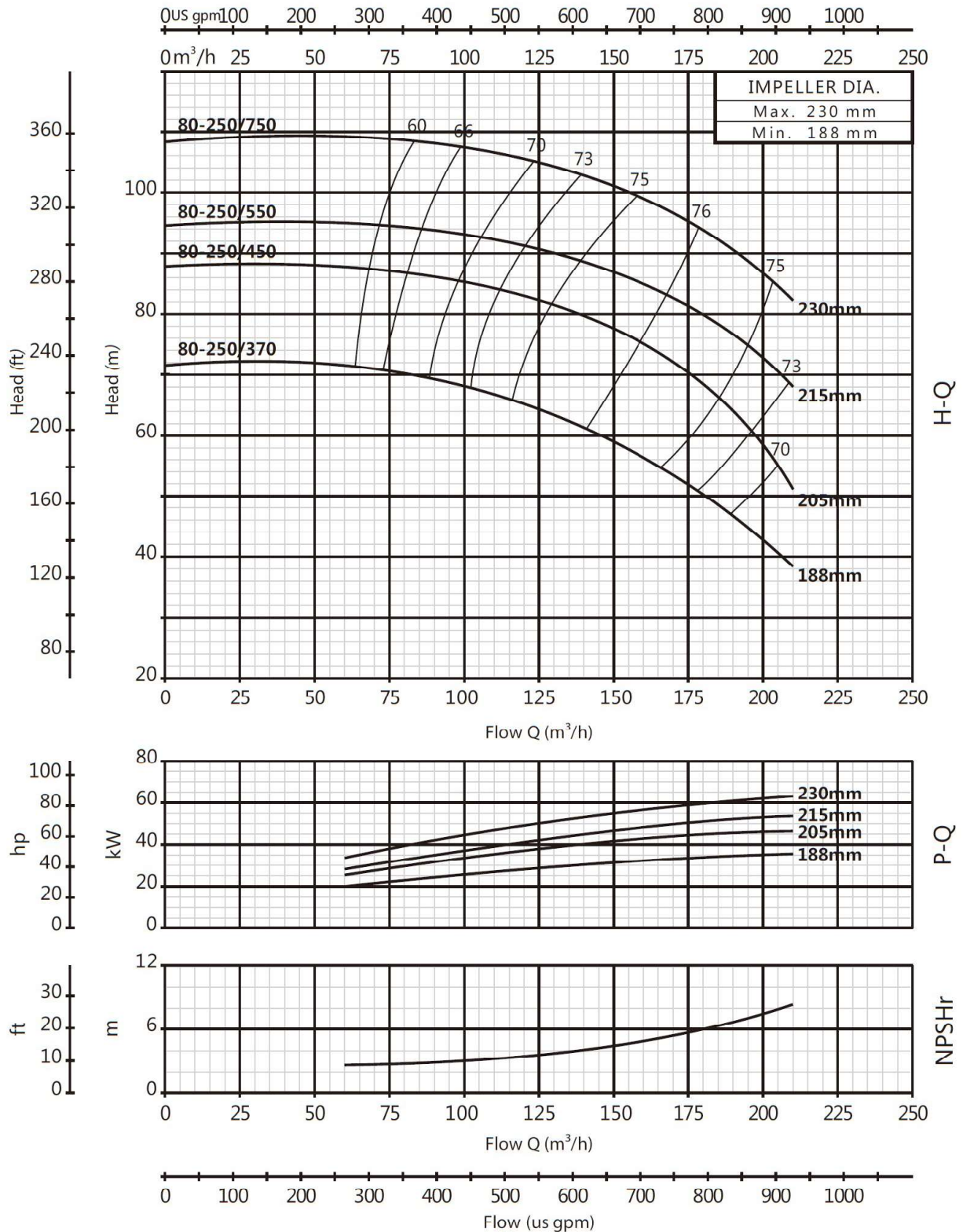

TECNODYNE

TECNODYNE PUMPS INC.

02 Sheppard Ave E, North York
Ontario, Canada M2N 5Y7
T: +1 (647) 255-2270
info@tecnodyne.ca
www.tecnodyne.ca

TECNODYNE (China) Ltd.

Suite C, Level 7, World Trust Tower
50 Stanley Street, Central
Hong Kong
hk@tecnodynepumps.com
www.tecnodynepumps.com